

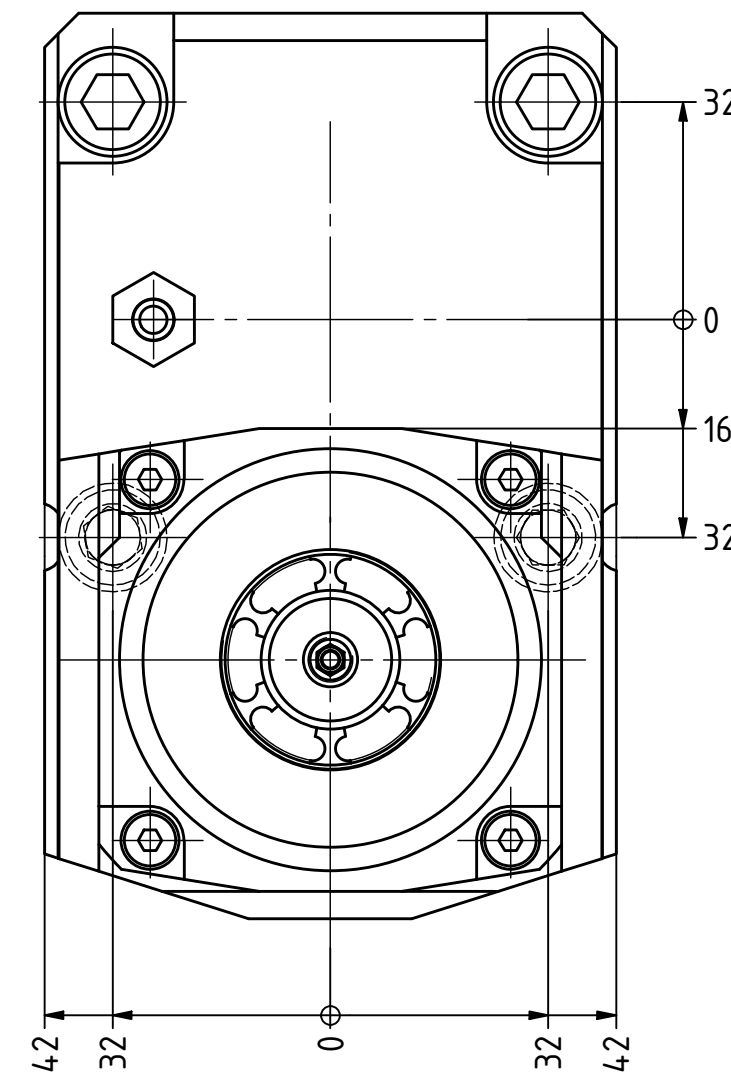

Ceramic Seal

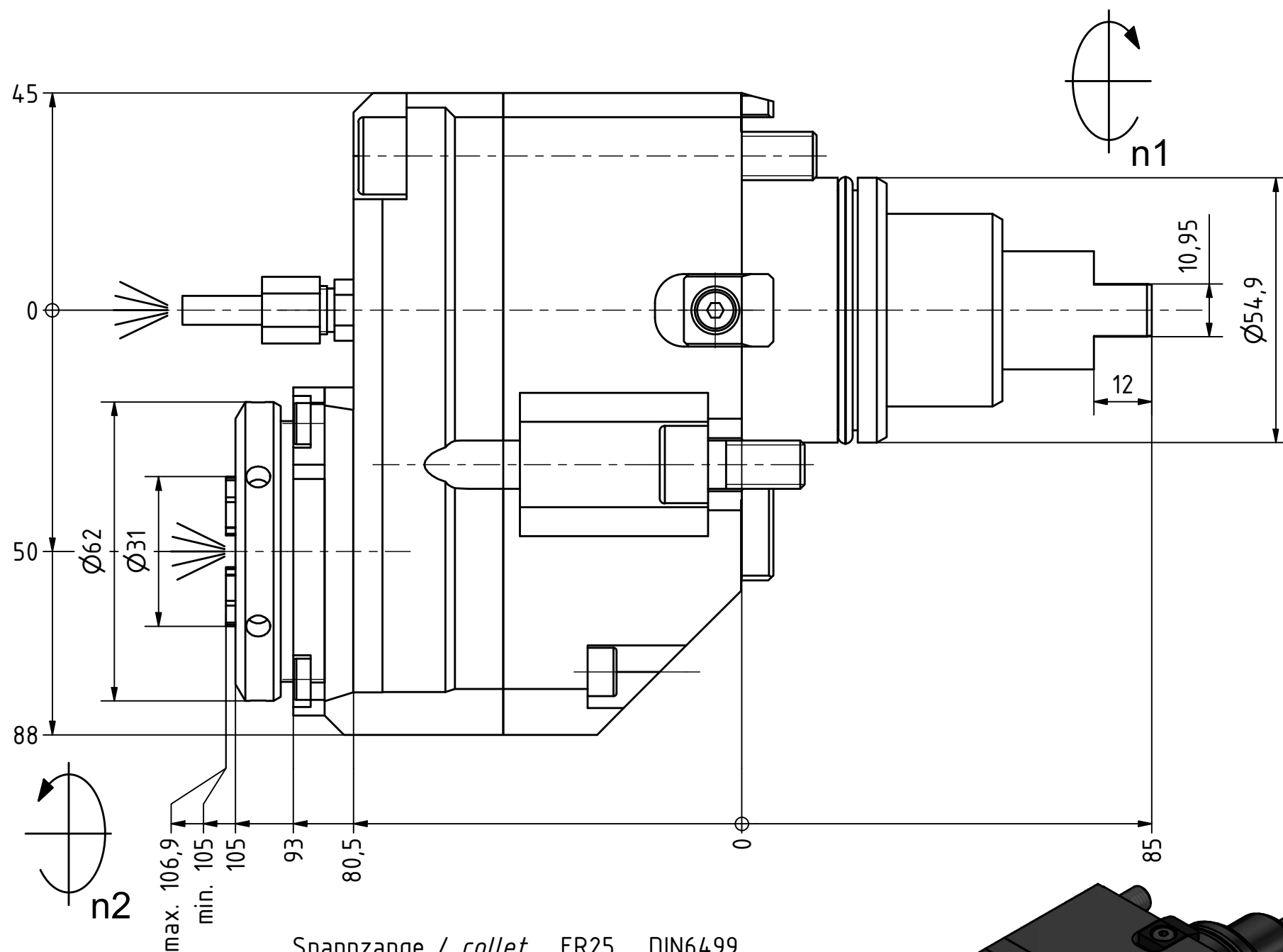

Tech Details



Spannzange / collet ER25 DIN6499  
 Spannbereich / clamping range: 1,0 - 16,0

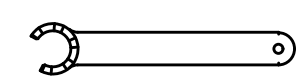
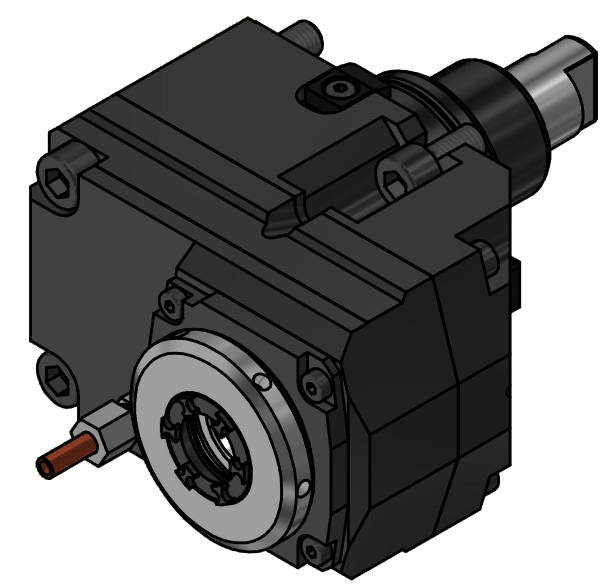

Spannzangenschlüssel für innenliegende Mutter  
 Clamping wrench for internal collet  
 225AX

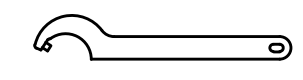

Hakenschlüssel mit Zapfen  
 Hook wrench with fixed pin  
 DIN1810 B 58x62

Copyright **EWS Tool Technologies**  
 Weitergabe und Vervielfältigung dieser Unterlage, Verwertung und Mitteilung ihres Inhalts nicht gestattet, soweit nicht ausdrücklich zugestanden. Zuwiderhandlungen verpflichten zu Schadenersatz.

Innen- und Aussenkuehlung / Inside and outside coolant supply  
 Kuehlmittelfiltrierung <math>50\mu</math> / coolant filtration <math>50\mu</math>  
 Achtung: genaue Übersetzung 1,963:1  
 Caution: exact gear ratio 1,963:1

Bemerkung - Note  
 Für Trockenlauf geeignet!  
 Use without coolant fluid allowed!

Technische Daten - technical data	
Weight	= 6.764 [kg]
Torque max. (M1/M2)	= 20 / 40 [Nm]
Speed max. (n1/n2)	= 6000 / 3000 [1/min]
Gear ratio (i)=n1:n2	= 2:1
Pressure (pmax)	= 70 [bar]

Benennung - Title  
**Axial Bohr u. Fräskopf achsversetzt**  
**Ax. drill. and mill. head offset**

**EWS** Tool Technologies  
 EWS Weigle GmbH & Co. KG  
 Maybachstr. 1  
 D-73066 UHINGEN  
 www.ews-tools.de

Technische Änderungen vorbehalten!  
 Subject to technical modifications!  
 IDENT: DEWS235580  
 Nr. - No. 50.5525VLHP2IKDI2IM

REV: -/A  
 MNR. 227684

