

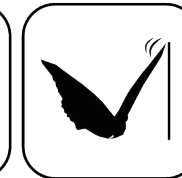

Ceramic Seal

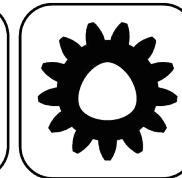

Butterfly Seal



Polygon Joint

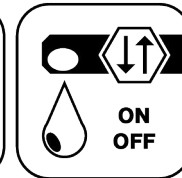

Coolant Management



Tech Details

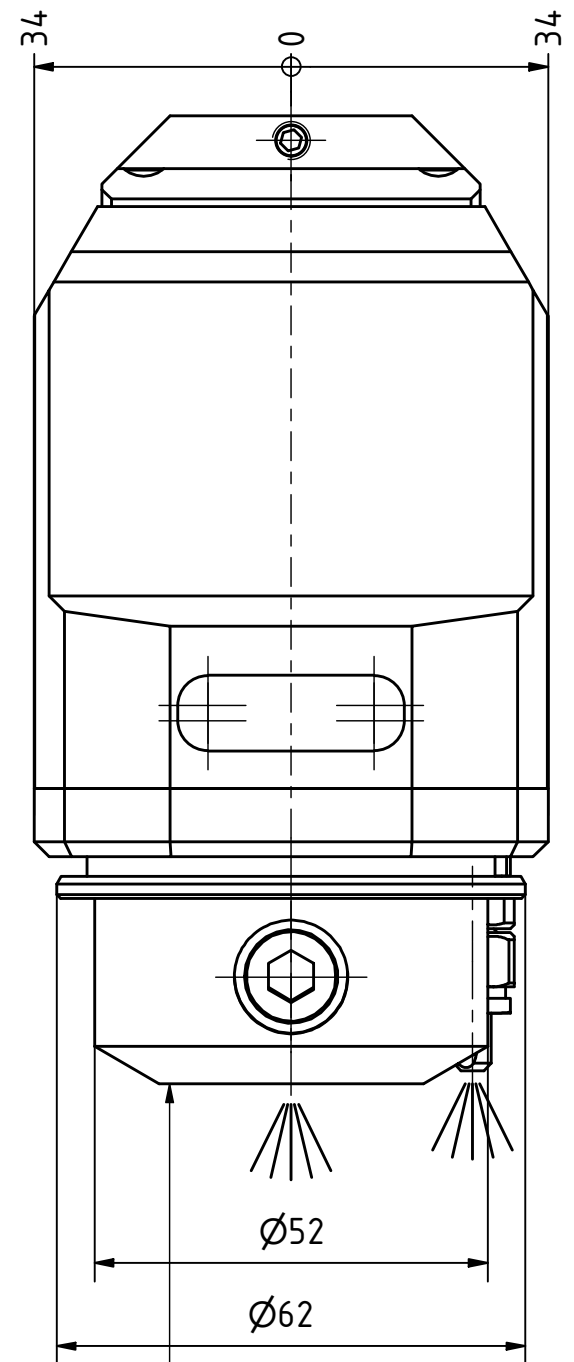
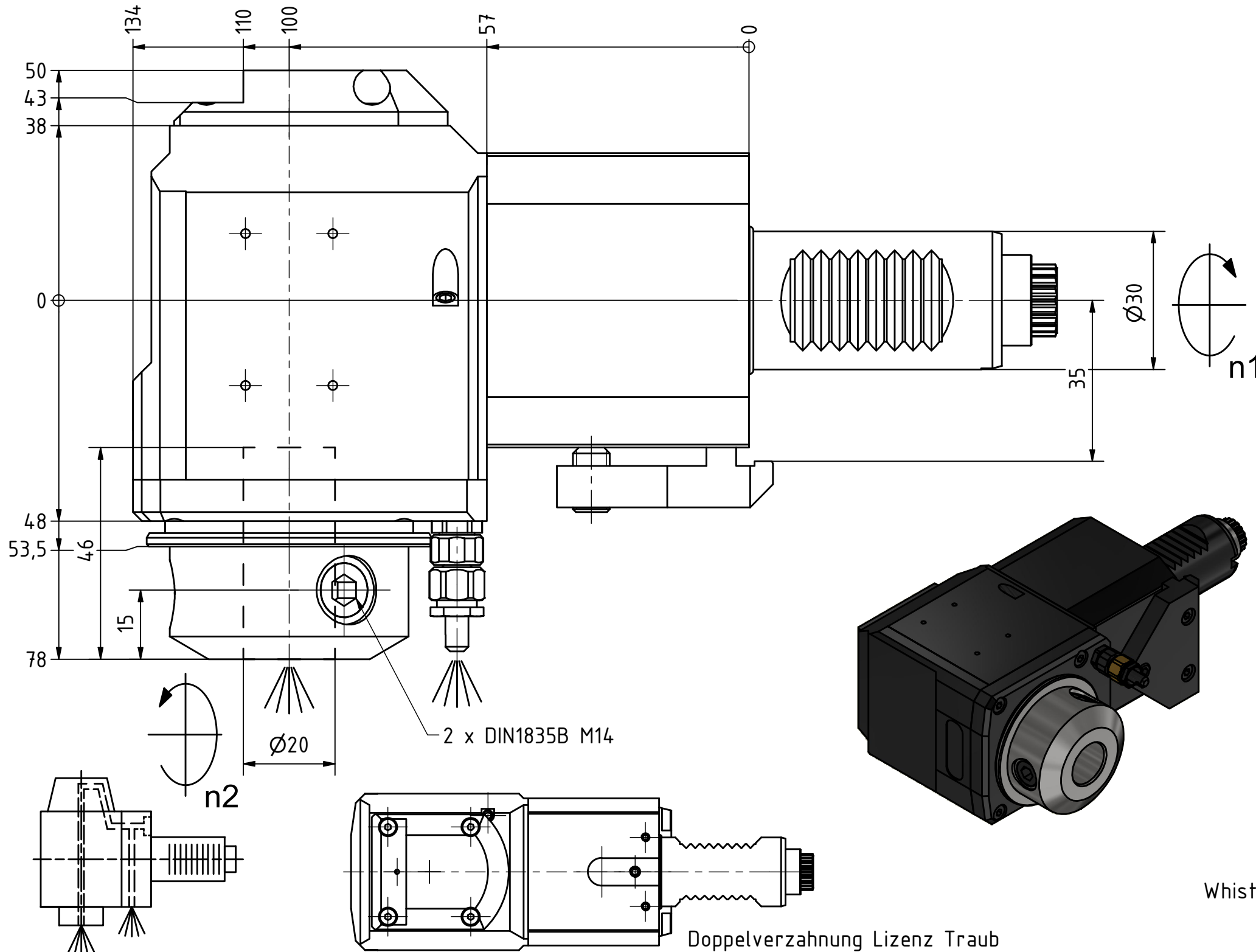

Whistle Notch / Weldon

Copyright **EWS Tool Technologies**  
Weitergabe und Vervielfaeltigung dieser Unterlage,  
Verwertung und Mitteilung ihres Inhalts nicht  
gestattet, soweit nicht ausdrucklich zugestanden.  
Zuwiderhandlungen verpflichten zu Schadenersatz.

Bemerkung - Note  
Für Trockenlauf geeignet!  
Use without coolant fluid allowed!  
mit Kegelrollenlager  
with taper roller bearing(s)

Technische Daten - technical data	
Weight	= 4.971 [kg]
Torque max. (M1/M2)	= 20 / 40 [Nm]
Speed max. (n1/n2)	= 6000 / 3000 [1/min]
Gear ratio (i)=n1:n2	= 2:1
Pressure (pmax)	= 70 [bar]

Benennung - Title  
**Radial Bohr und Fräskopf**  
**Radial drilling and milling head**



Nr. - No.  
**60.3020WNKRE365RLIKDI2EL**

Technische Aenderungen vorbehalten!  
Subject to technical modifications!  
IDENT: DEWS234390

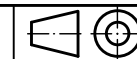

REV: -/A

MNR.  
**227542**

