

Spannzange / collet ER25 DIN6499
 Spannbereich / clamping range: 1,0 - 16,0

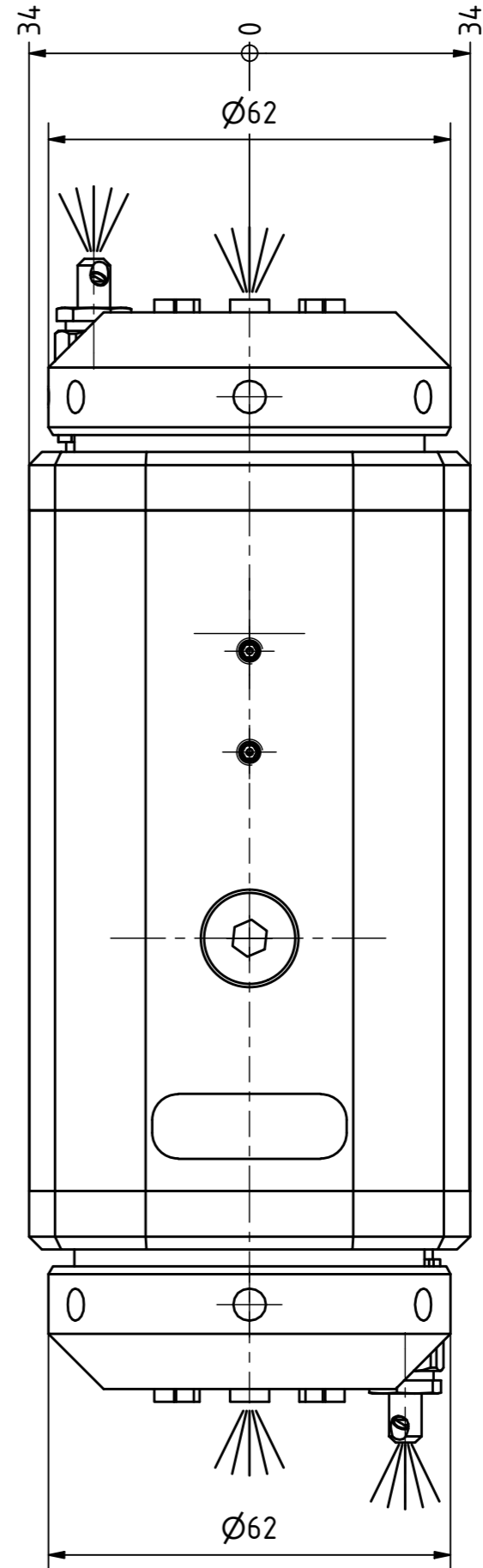

Spannzange / collet ER25 DIN6499
 Spannbereich / clamping range: 1,0 - 16,0

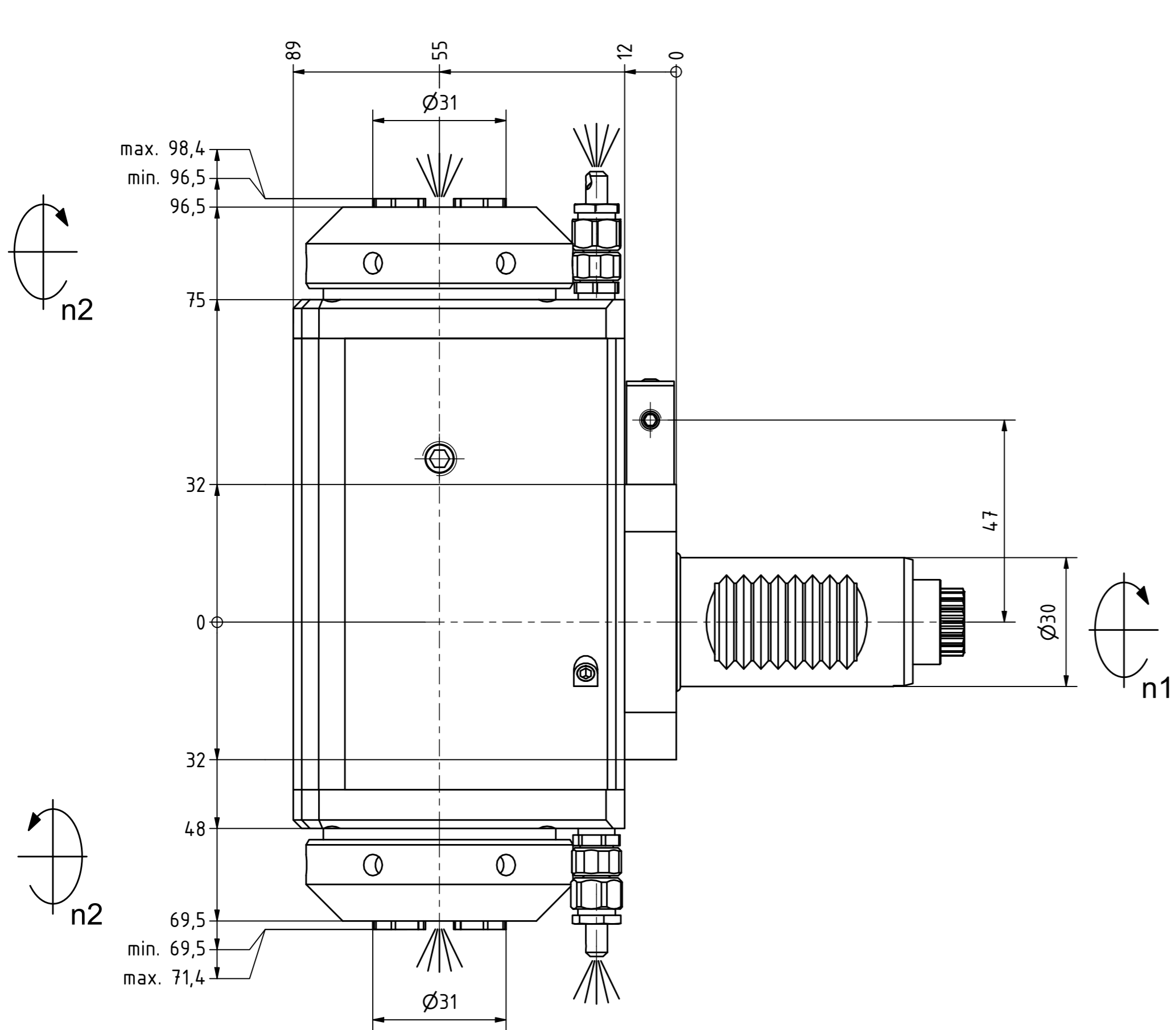
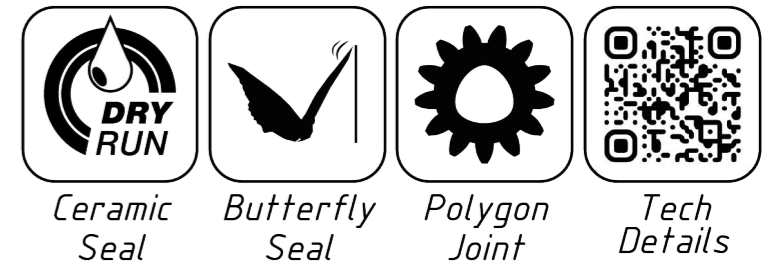
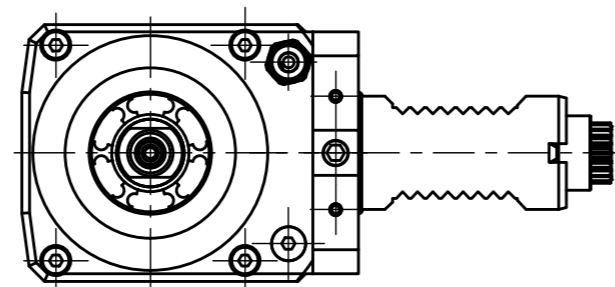

Doppelverzahnung Lizenz Traub
 double tooth system licence Traub

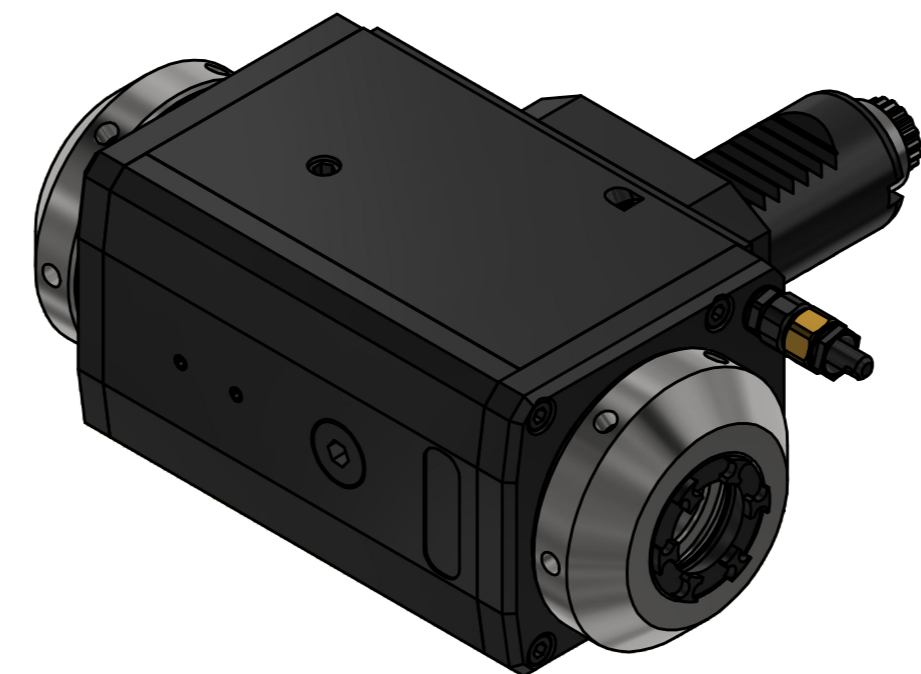

Spannzangenschlüssel für innenliegende Mutter
 Clamping wrench for internal collet
 225AX

Hakenschlüssel mit Zapfen
 Hook wrench with fixed pin
 DIN1810 B 58x62

Copyright EWS Tool Technologies
 Weitergabe und Vervielfältigung dieser Unterlage, Verwertung und Mitteilung ihres Inhalts nicht gestattet, soweit nicht ausdrücklich zugestanden. Zuwiderhandlungen verpflichten zu Schadenersatz.

Innen- und Aussenkuehlung / Inside and outside coolant supply
 Kuehlmittelfiltrierung=50µ / coolant filtration=50µ

Bemerkung - Note	Technische Daten - technical data
Für Trockenlauf geeignet! Use without coolant fluid allowed!	Weight = 5.506 [kg] Torque max. (M1/M2) = 32 / 32 32 [Nm] Speed max. (n1/n2) = 8000 / 8000 8000 [1/min] Gear ratio (i)=n1:n2 = 1:1 1:1 Pressure (pmax) = 70 [bar]

Benennung - Title
Radial Bohr und Fräskopf
Radial drilling and milling head

EWS Weigle GmbH & Co. KG Maybachstr. 1 D-73066 Ulm/geren www.ews-tool.de	Technische Änderungen vorbehalten! Subject to technical modifications! IDENT: DEWS240989	REV: -/A MNR.	
	Nr. - No. 60.3025DCTXRLIKCIM	227487	