

Platzverhältnisse / space conditions Nakamura MX-100

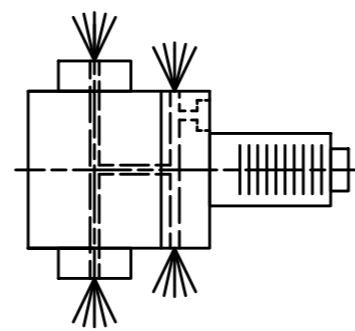

Innen- und Aussenkuehlung / Inside and outside coolant supply
Kuehlmittelfiltrierung-50µ / coolant filtration-50µ

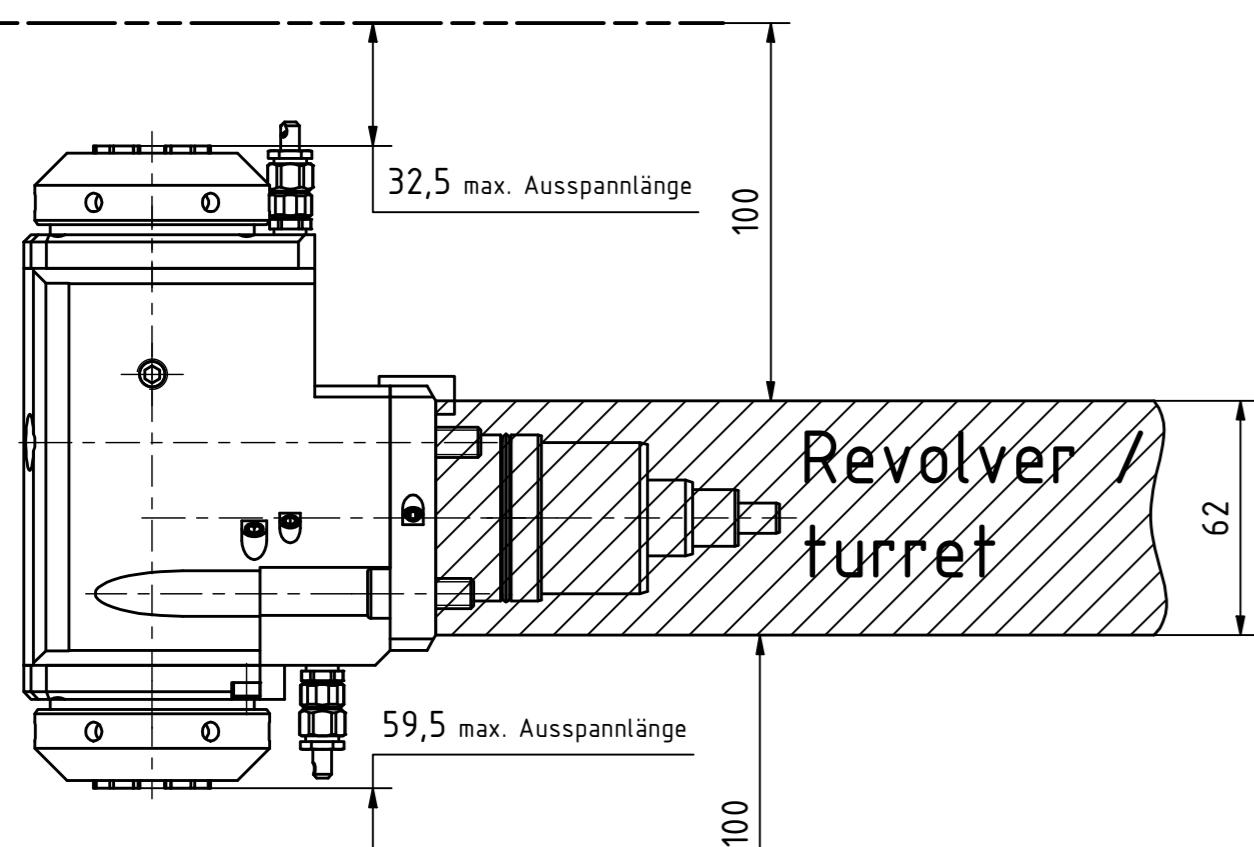
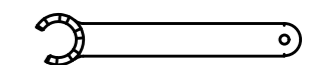
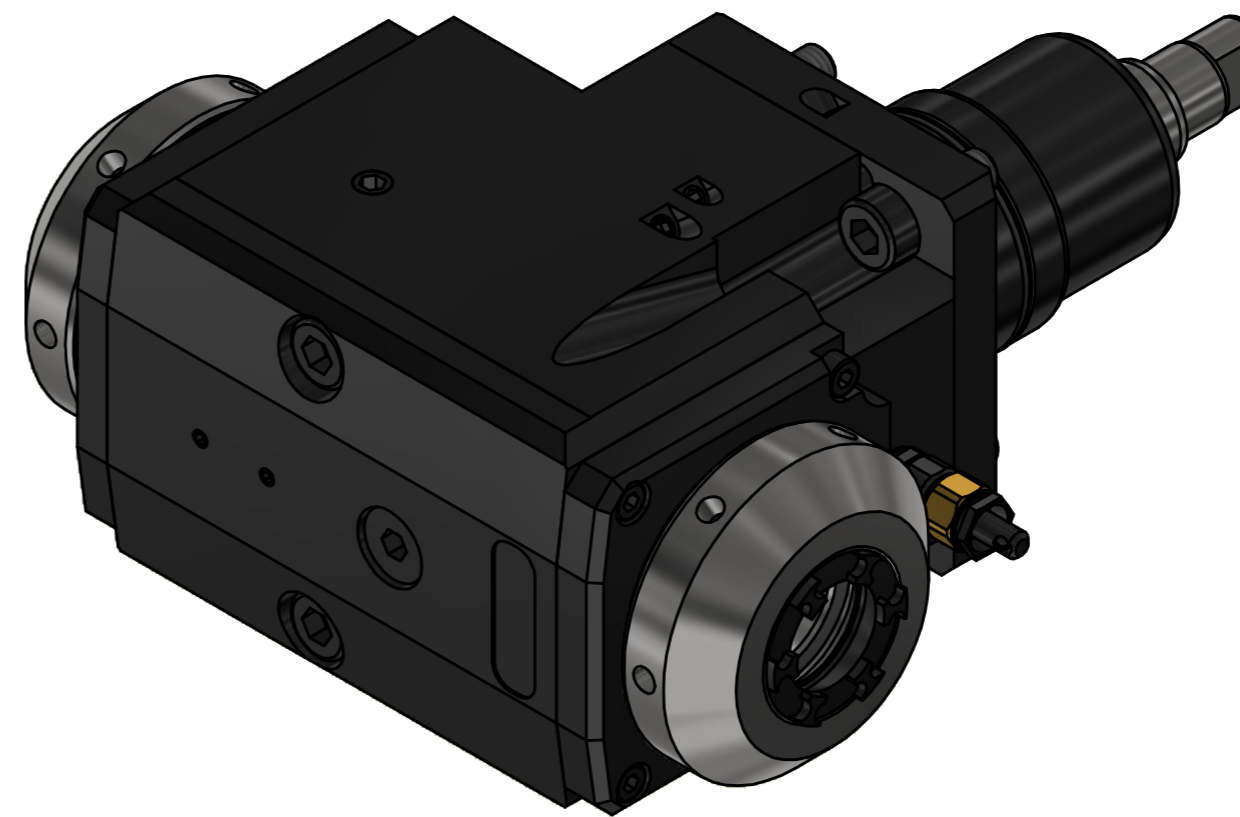

Spannzangenschlüssel für innenliegende Mutter
Clamping wrench for internal collet
225AX

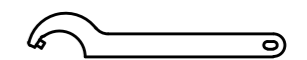

Hakenschlüssel mit Zapfen
Hook wrench with fixed pin
DIN1810 B 58x62

Copyright EWS Tool Technologies
Weitergabe und Vervielfaeltigung dieser Unterlage, Verwertung und Mitteilung ihres Inhalts nicht gestattet, soweit nicht ausdruecklich zugestanden. Zuwiderhandlungen verpflichten zu Schadenersatz.

Bemerkung - Note

Für Trockenlauf geeignet!
Use without coolant fluid allowed!

Technische Daten - technical data

Weight = 7.080 [kg]
Torque max. (M1/M2) = 25 / 25 | 25 [Nm]
Speed max. (n1/n2) = 6000 / 6000 | 6000 [1/min]
Gear ratio (i)=n1:n2 = 1:1 | 1:1
Pressure (pmax) = 70 [bar]

Benennung - Title

Radial Bohr und Fräskopf
Radial drilling and milling head

EWS Tool Technologies
EWS Weigle GmbH & Co. KG
Maybachstr. 1
D-73066 Uhlingen
www.ews-tool.de

Technische Aenderungen vorbehalten!
Subject to technical modifications!

IDENT: DEWS239987

REV: -/B

Nr. - No.
60.44.25DNTY3IKCIMX75

MNR.
227369

