

Spannzange / collet ER20 DIN6499
 Spannbereich / clamping range: 1,0 - 13,0

Gewindebohrzange / tapping collet
 ET-1-20 M2-M6

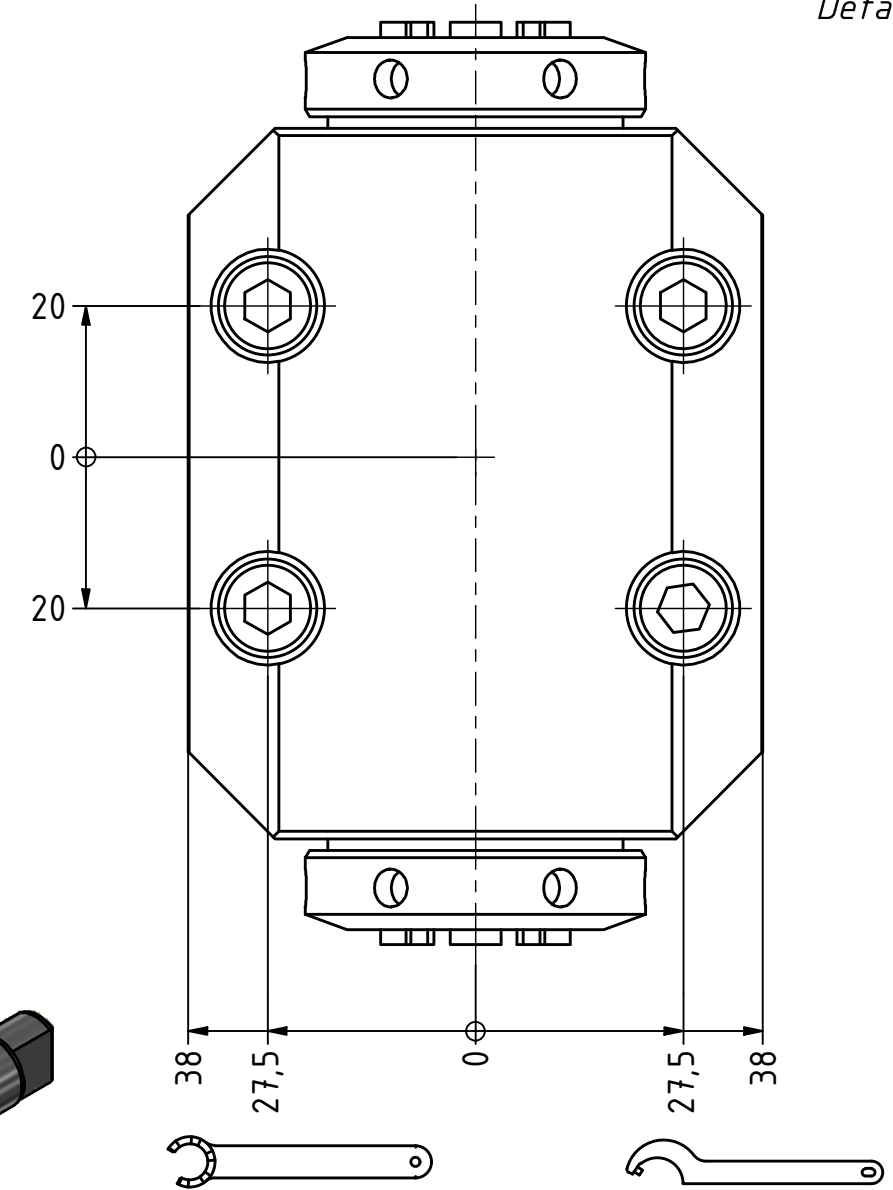
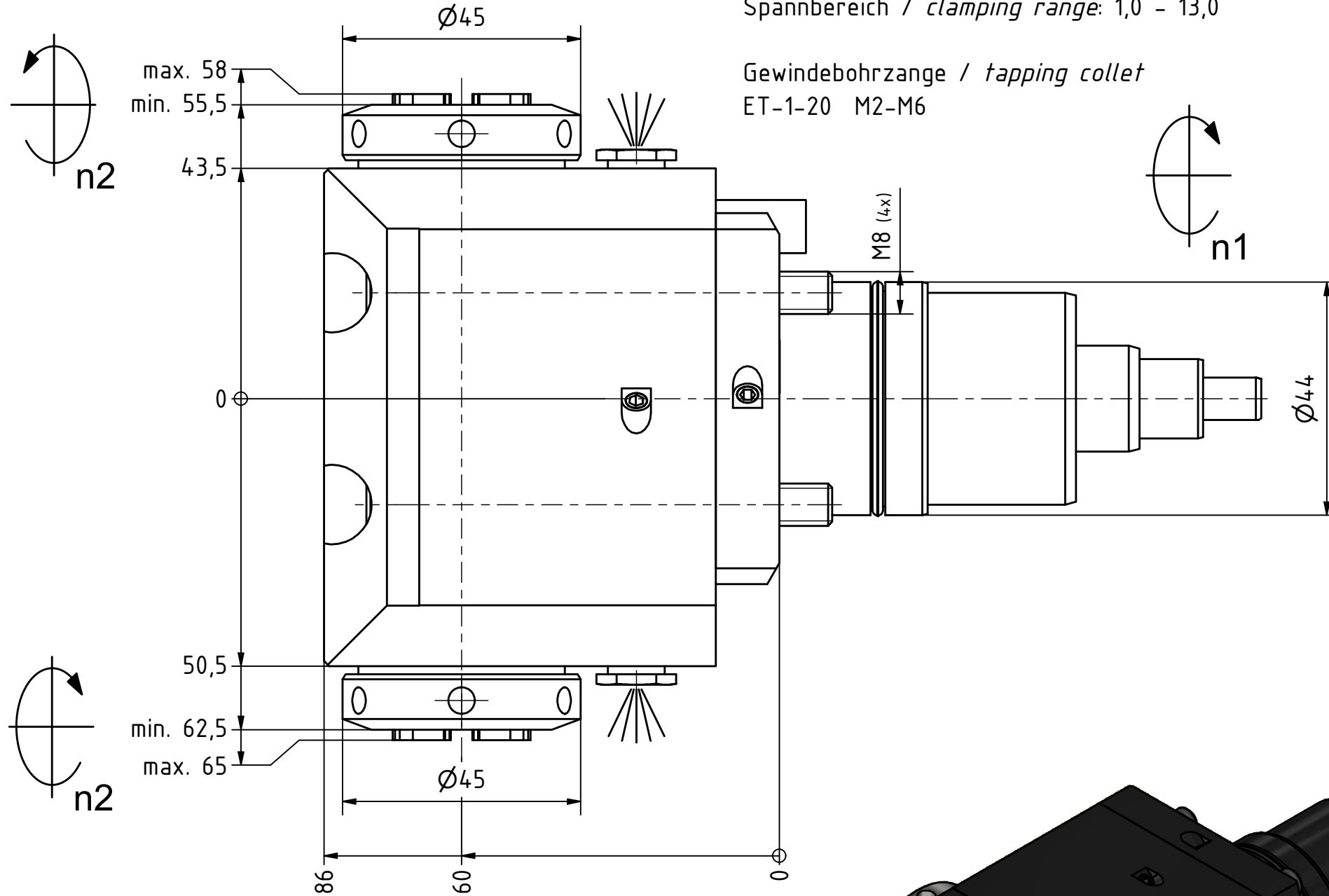
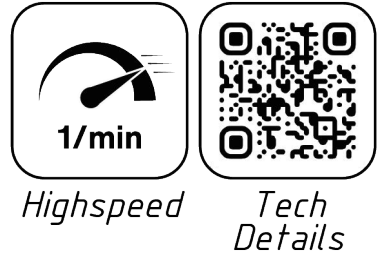

Spannzangenschlüssel für
 innenliegende Mutter
 Clamping wrench for
 internal collet
 220AX

Hakenschlüssel
 mit Zapfen
 Hook wrench
 with fixed pin
 DIN1810 B 45x50

Spannzange / collet ER20 DIN6499
 Spannbereich / clamping range: 1,0 - 13,0

Gewindebohrzange / tapping collet
 ET-1-20 M2-M6

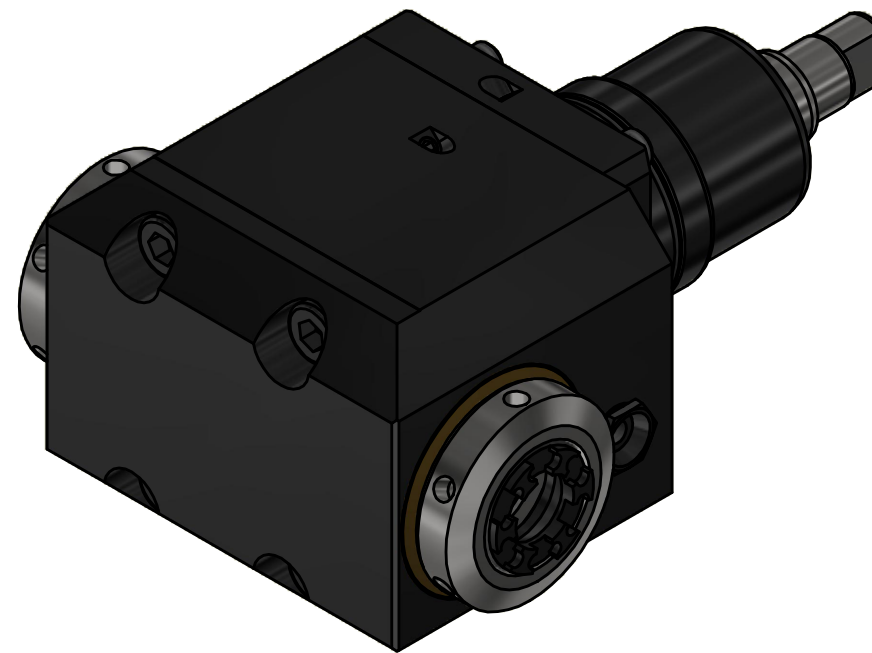

Copyright **EWS Tool Technologies**
 Weitergabe und Vervielfaeltigung dieser Unterlage,
 Verwertung und Mitteilung ihres Inhalts nicht
 gestattet, soweit nicht ausdrecklich zugestanden.
 Zuwiderhandlungen verpflichten zu Schadenersatz.

Bemerkung - Note	Technische Daten - technical data Weight = 4.669 [kg] Torque max. (M1/M2) = 25 / 25 [Nm] Speed max. (n1/n2) = 10000 / 10000 [1/min] Gear ratio (i)=n1:n2 = 1:1 1:1	Benennung - Title Radial Bohr und Fräskopf Radial drilling and milling head	EWS Tool Technologies EWS Weigle GmbH & Co. KG Maybachstr. 1 D-73066 Utingen www.ews-tools.de	Technische Aenderungen vorbehalten! Subject to technical modifications! IDENT: DEWS231280 Nr. - No. 60.4420DNTY3IMHSD10	 REV: -/A MNR. 227099	QR
------------------	--	---	---	--	---------------------------------------	-----------