

Highspeed

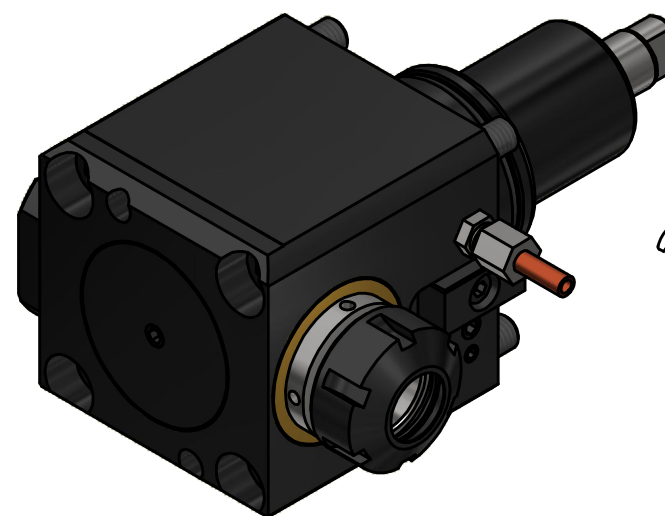

Tech Details

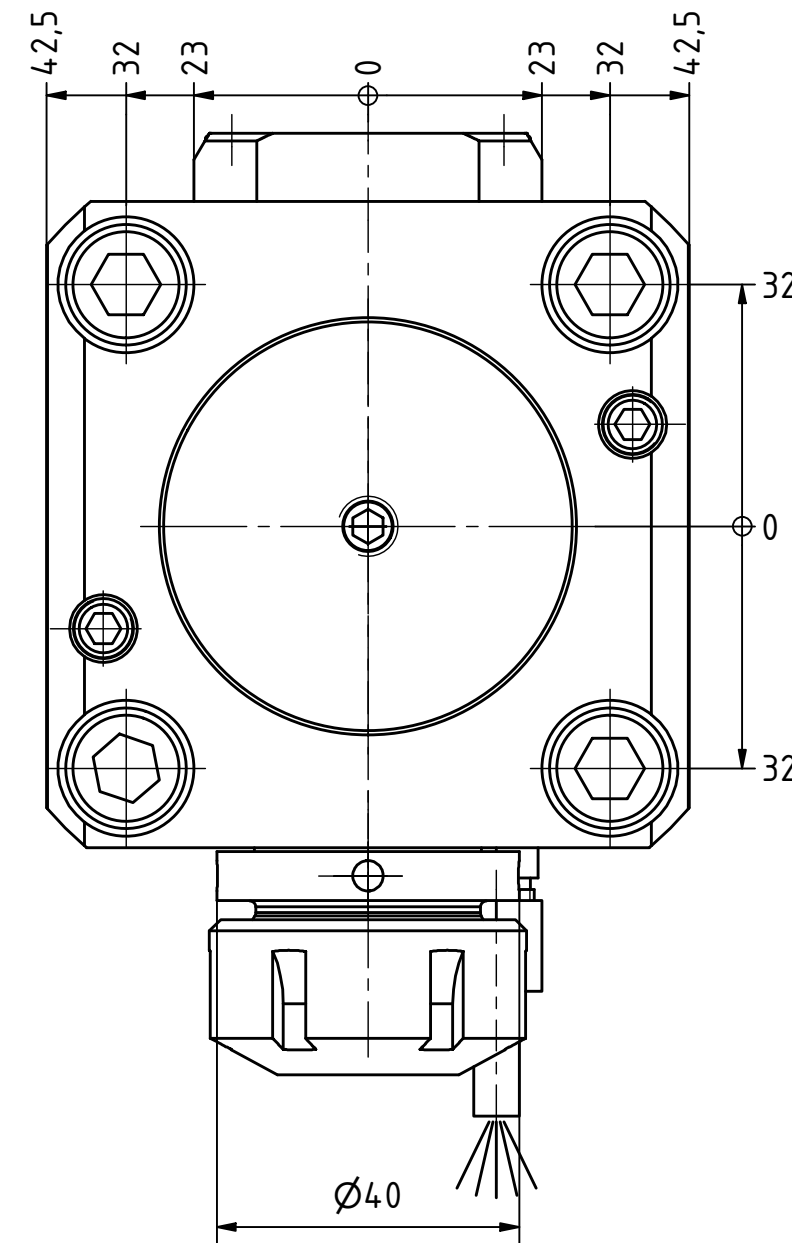
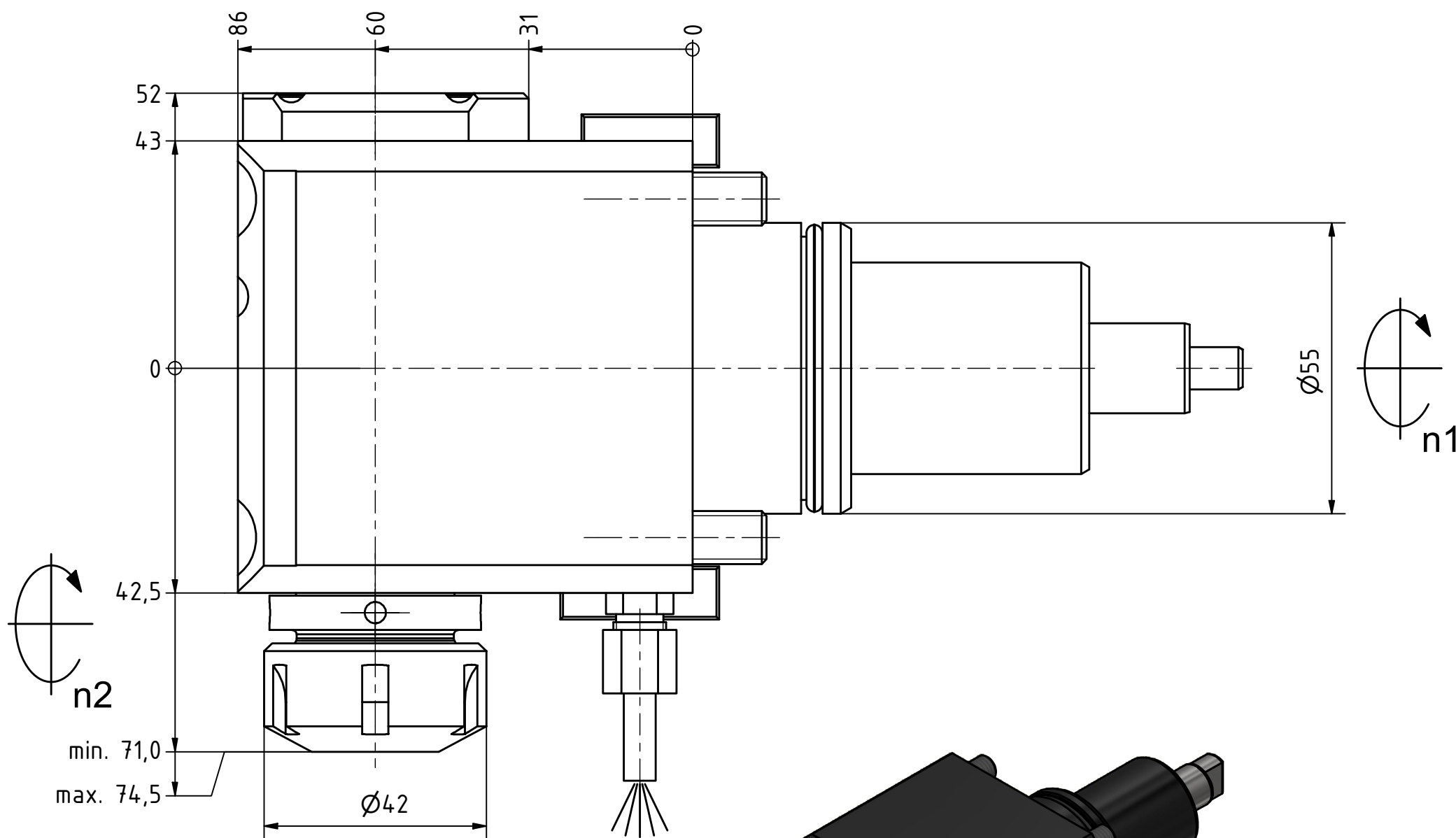

  
 Hakenschlüssel  
 mit Zapfen  
 Hook wrench  
 with fixed pin  
 DIN1810 B 40x42

  
 Spannzangenschlüssel  
 Clamping wrench  
 225

Spannzange / collet ER25 DIN6499  
 Spannbereich / clamping range: 1,0 - 16,0

Gewindebohrzange / tapping collet  
 ET-1-25 M3-M10

Copyright **EWS Tool Technologies**  
 Weitergabe und Vervielfältigung dieser Unterlage,  
 Verwertung und Mitteilung ihres Inhalts nicht  
 gestattet, soweit nicht ausdrücklich zugestanden.  
 Zuwiderhandlungen verpflichten zu Schadenersatz.

Bemerkung - Note

Technische Daten - technical data

Benennung - Title

Weight = 5.258 [kg]  
 Torque max. (M1/M2) = 25 / 25 [Nm]  
 Speed max. (n1/n2) = 12000 / 12000 [1/min]  
 Gear ratio (i)=n1:n2 = 1:1

**Radial Bohr und Fräskopf**  
**Radial drilling and milling head**



Nr. - No.  
**60.55251809N4GLHSD12**

Technische Änderungen vorbehalten!  
 Subject to technical modifications!

IDENT: DEWS229394



REV: -/A

MNR.

226901

