



Highspeed



Tech
Details

Spannzange / collet ER25 DIN6499
Spannbereich / clamping range: 1,0 - 16,0

Gewindebohrzange / tapping collet
ET-1-25 M3-M12

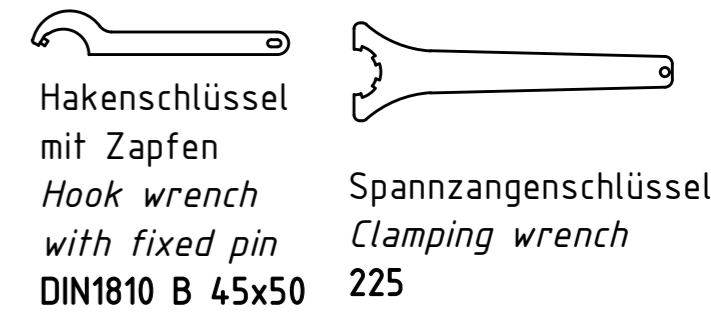
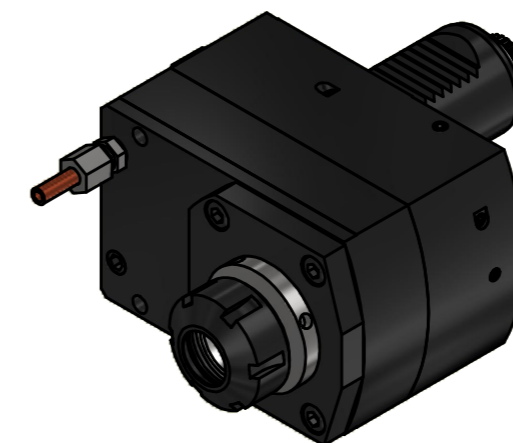
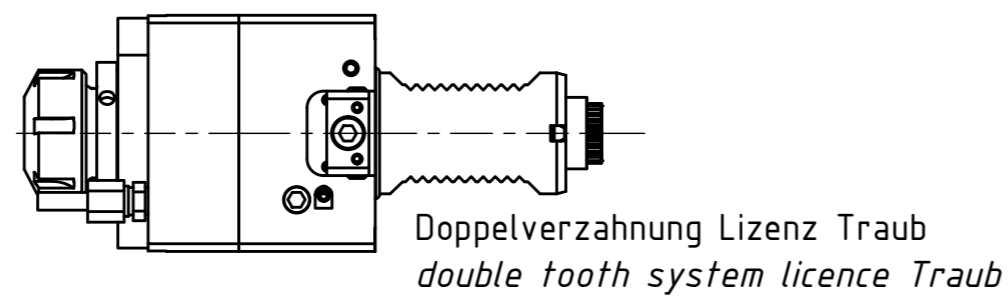
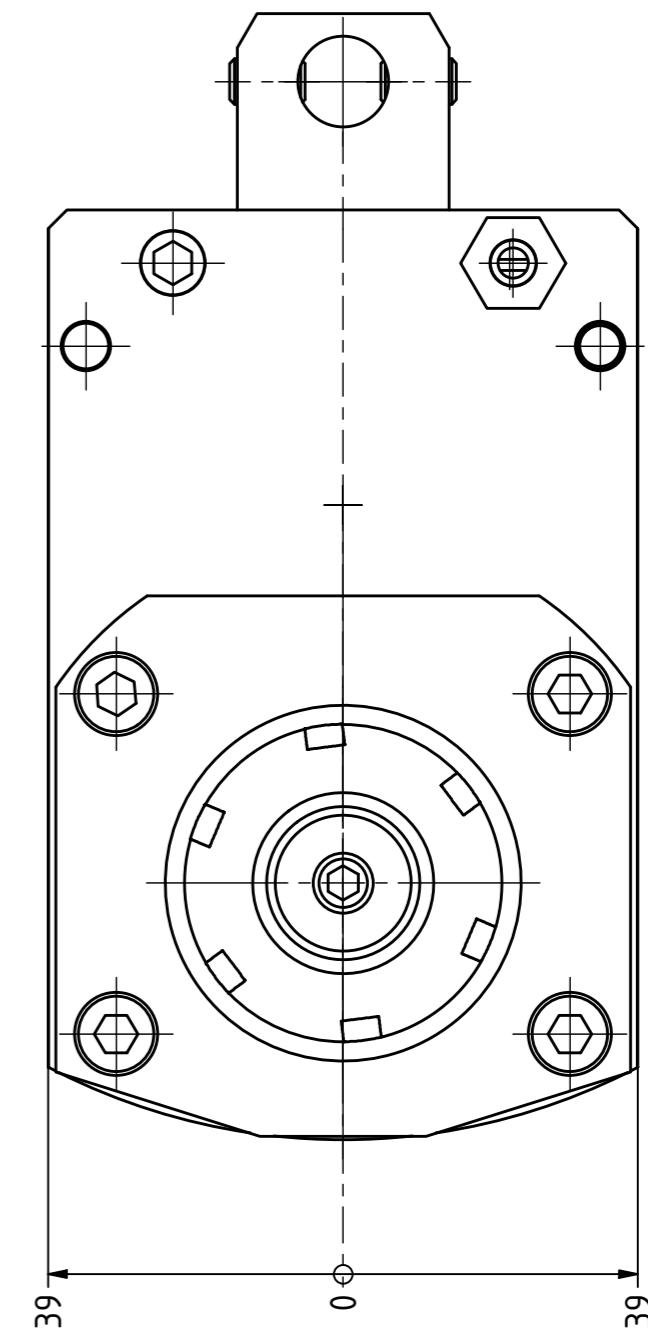
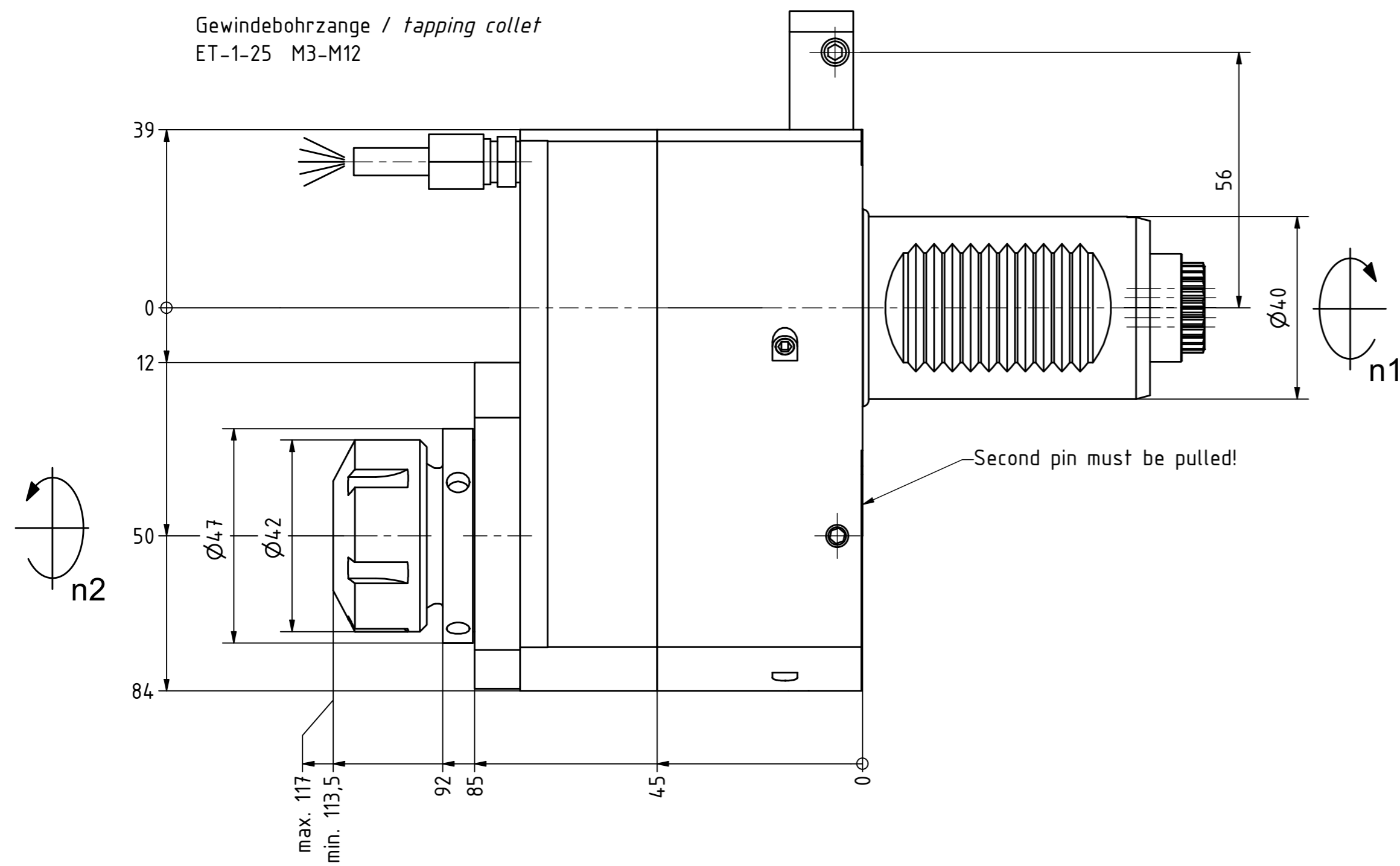

Copyright **EWS Tool Technologies**
Weitergabe und Vervielfältigung dieser Unterlage, Verwertung und Mitteilung ihres Inhalts nicht gestattet, soweit nicht ausdrücklich zugestanden. Zuwiderhandlungen verpflichten zu Schadenersatz.

Bemerkung - Note

Technische Daten - technical data

Weight = 5,094 [kg]
Torque max. (M1/M2) = 50 / 25 [Nm]
Speed max. (n1/n2) = 6000 / 12000 [1/min]
Gear ratio (i)=n1:n2 = 1:2

Benennung - Title

Axial Bohr u. Fräskopf achsversetzt
Ax. drill. and mill. head offset

EWS Tool Technologies
EWS Weigle GmbH & Co. KG
Maybachstr. 1
D-73066 Ulm/ingen
www.ews-tools.de

Technische Änderungen vorbehalten!
Subject to technical modifications!

IDENT: DEWS228997

REV: -/A

Nr. - No.
50.4025CTXRL1-S01

MNR.
226888

QR