

Spannzange / collet ER25 DIN6499
Spannbereich / clamping range: 1,0 - 16,0

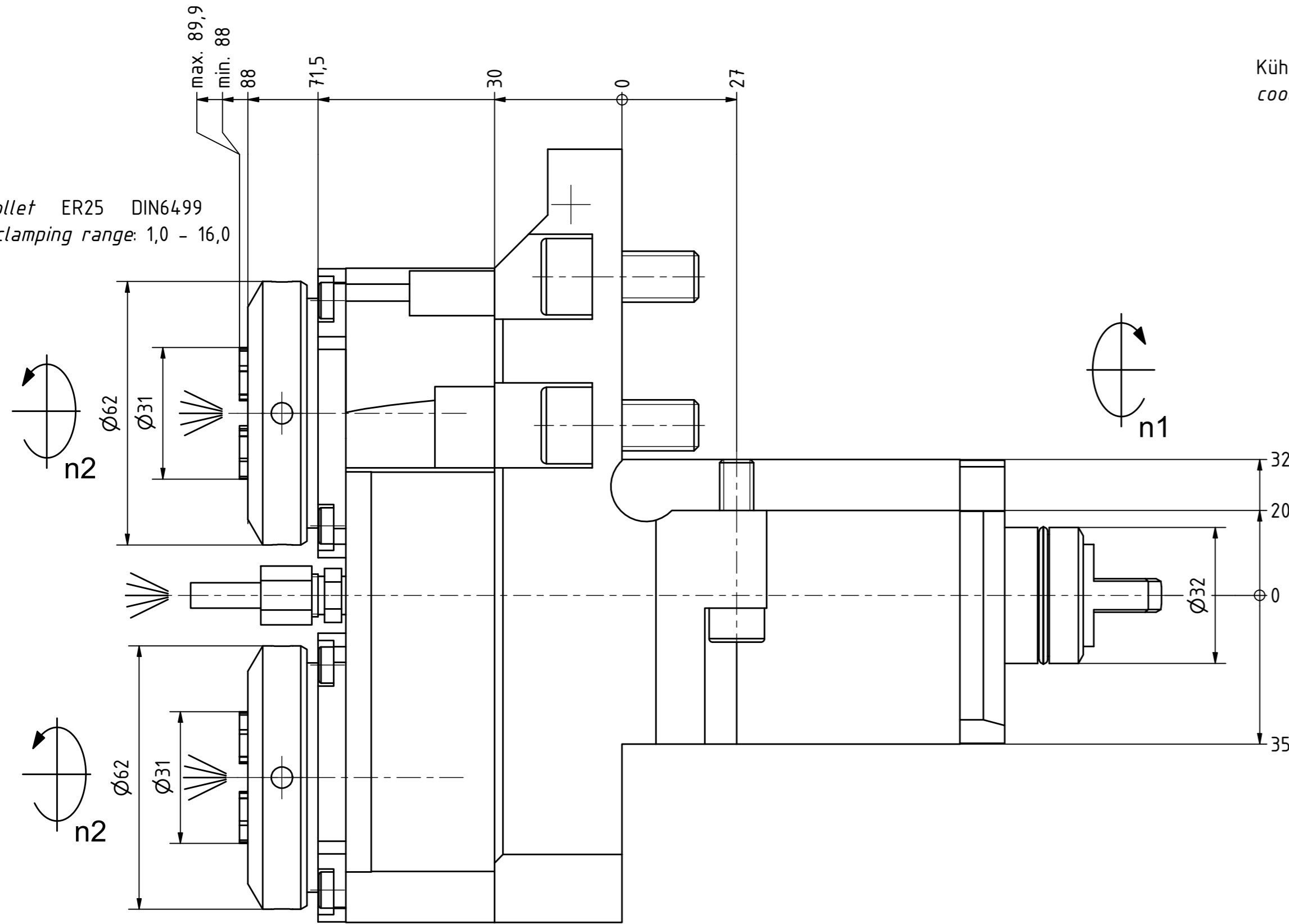

Spannzange / collet ER25 DIN6499
Spannbereich / clamping range: 1,0 - 16,0

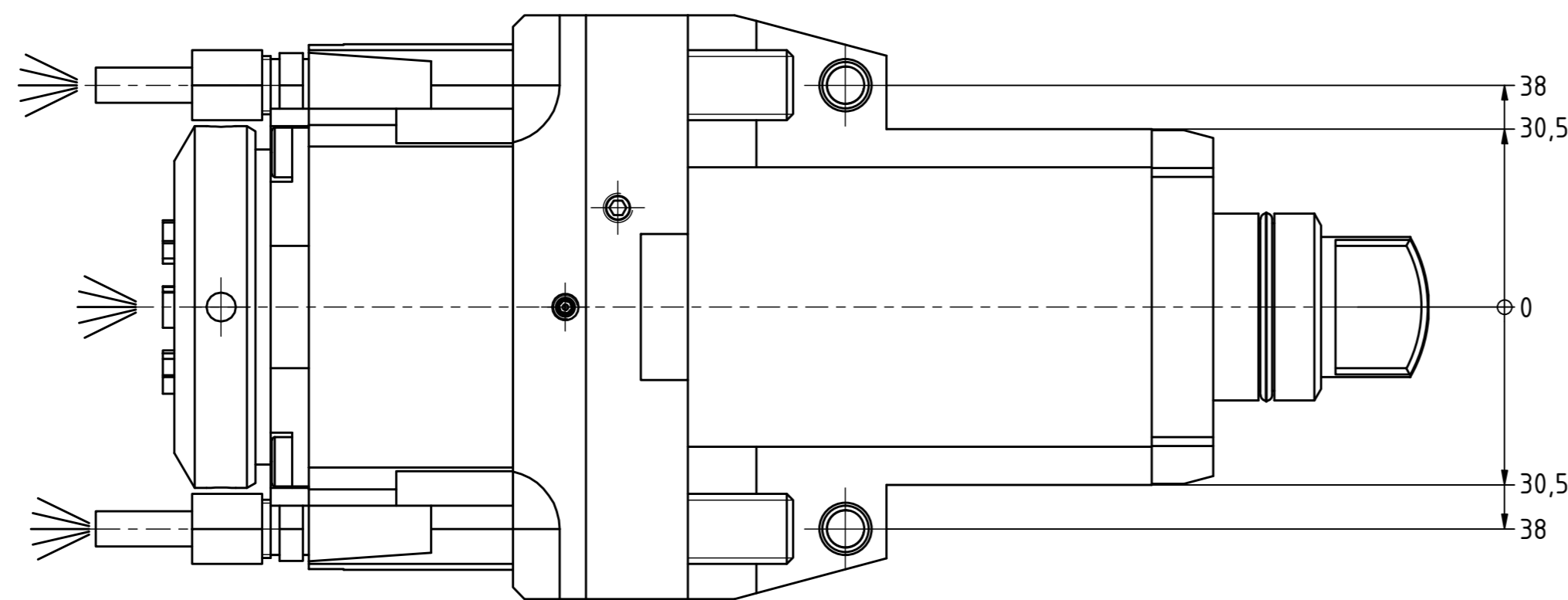

Kühlmittelübergabe
coolant supply

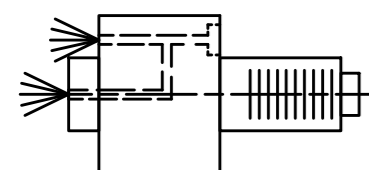
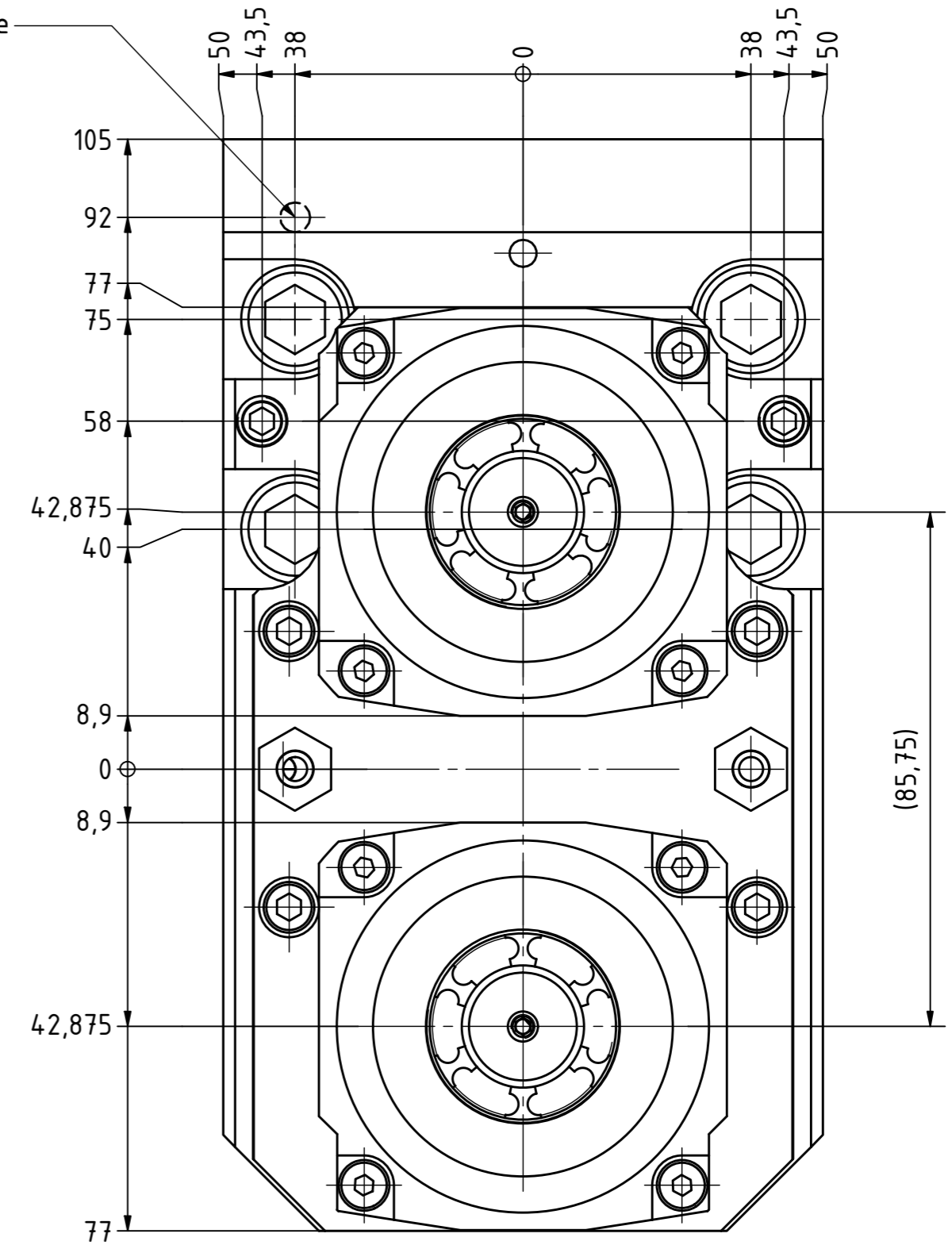

Innen- und Aussenkuehlung / Inside and outside coolant supply
Kuehlmittefiltrierung=50µ / coolant filtration=50µ

Bemerkung - Note
Für Trockenlauf geeignet!
Use without coolant fluid allowed!

Technische Daten - technical data
Weight = 10,244 [kg]
Torque max. (M1/M2) = 16 / 4 | 4 [Nm]
Speed max. (n1/n2) = 6000 / 12000 | 12000 [1/min]
Gear ratio (i)=n1:n2 = 1:2 | 1:2
Pressure (pmax) = 70 [bar]

Benennung - Title
Axial Bohr und Fräskopf
Axial drilling and milling head

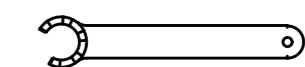
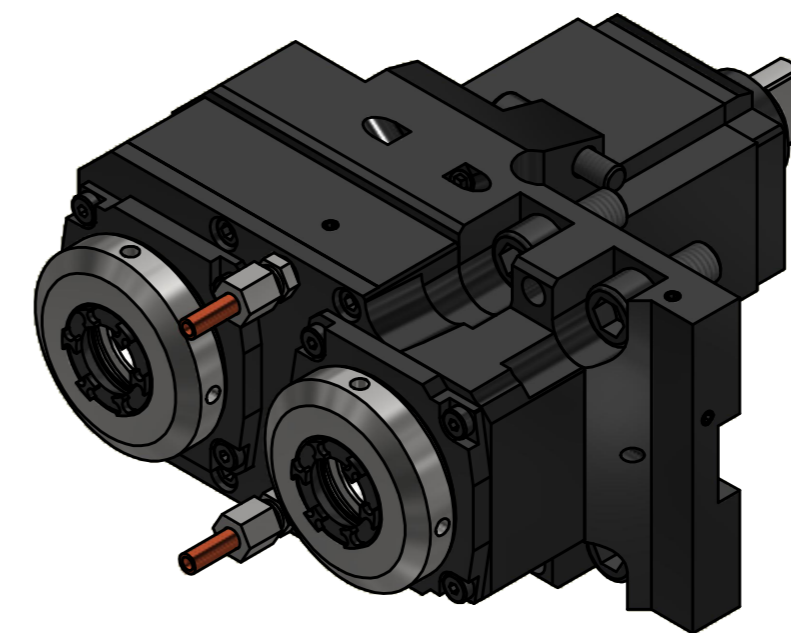

Spannzangenschlüssel für
innenliegende Mutter
Clamping wrench for
internal collet
225AX

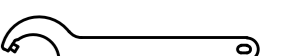

Hakenschlüssel
mit Zapfen
Hook wrench
with fixed pin
DIN1810 B 58x62

Copyright EWS Tool Technologies
Weitergabe und Vervielfältigung dieser Unterlage,
Verwertung und Mitteilung ihres Inhalts nicht
gestattet, soweit nicht ausdrücklich zugestanden.
Zuwendungen verpflichten zu Schadenersatz.

	<small>EWS Weigle GmbH & Co. KG Maybachstr. 1 D-73066 Ulm/Ingen www.ews-tool.de</small>	<small>Technische Änderungen vorbehalten! Subject to technical modifications!</small>	
		<small>IDENT: DEWS233146</small>	
<small>Nr. - No.</small> 40.3225DZSL200BMTIKD1IMTK85.75	<small>MNR.</small> 226869		