

Kühlmittelübergabe
coolant supply

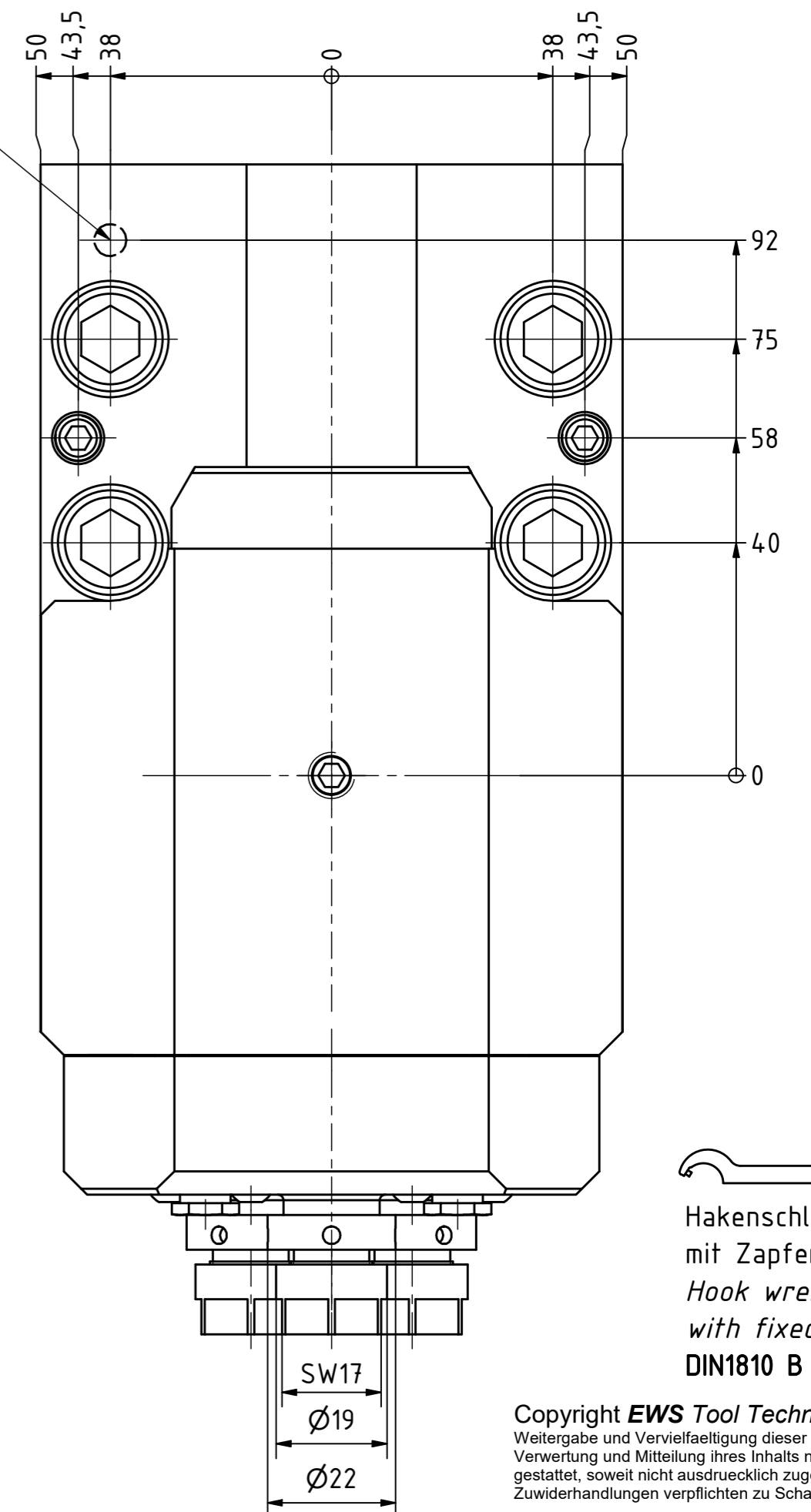

Hakenschlüssel
mit Zapfen
Hook wrench
with fixed pin
DIN1810 B 20x22

Copyright **EWS Tool Technologies**
Weitergabe und Vervielfältigung dieser Unterlage,
Verwertung und Mitteilung ihres Inhalts nicht
gestattet, soweit nicht ausdrücklich zugestanden.
Zuwendungen verpflichten zu Schadenersatz.

Spannzange / Collet ER11 DIN6499
Spannbereich / Clamping range: 0,5 - 7,0

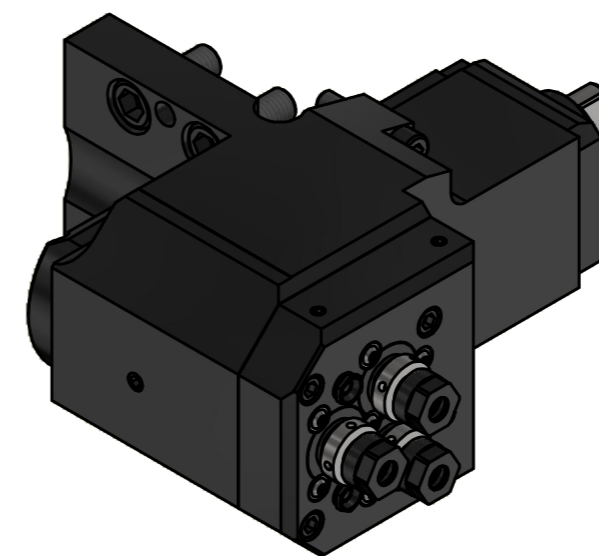
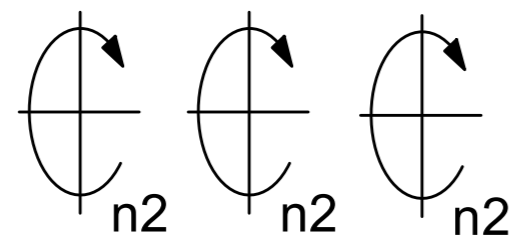

Bemerkung - Note

Technische Daten - technical data
Weight = 10.324 [kg]
Torque max. (M1/M2) = 12 / 2 | 2 | 2 [Nm]
Speed max. (n1/n2) = 6000/12000|12000|2000 [1/min]
Gear ratio (i)=n1:n2 = 1:2 | 1:2 | 1:2

Benennung - Title

Radial Bohr und Fräskopf
Radial drilling and milling head



Nr. - No.
60.3211TSL200BMT1TK32

Technische Änderungen vorbehalten!
Subject to technical modifications!
IDENT: DEWS233183

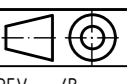

REV: -/B
MNR.
226870

