

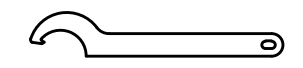

Highspeed

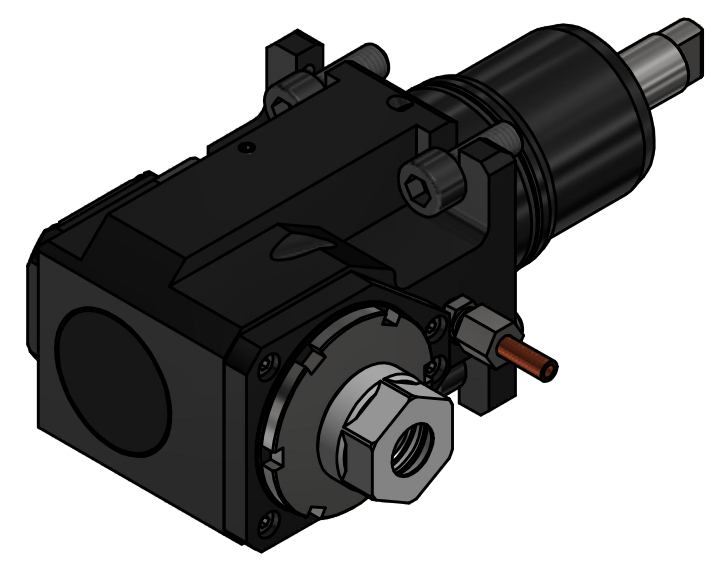

Tech Details

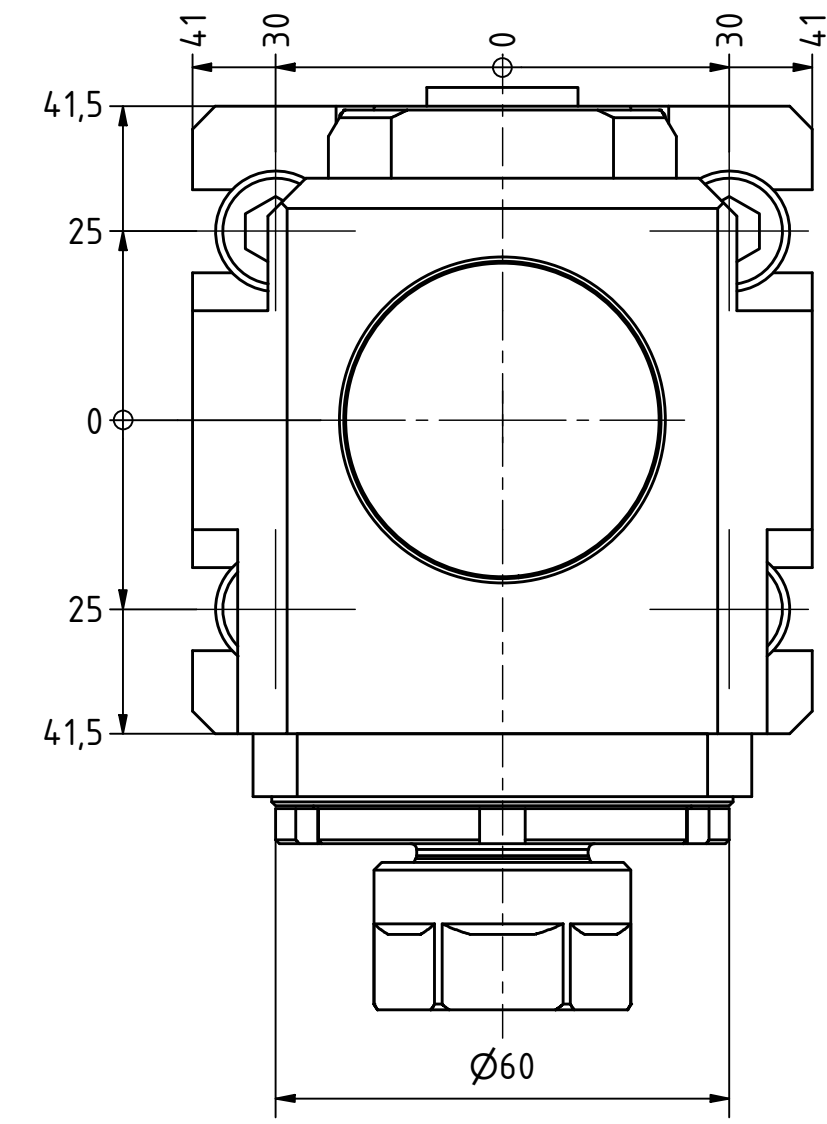
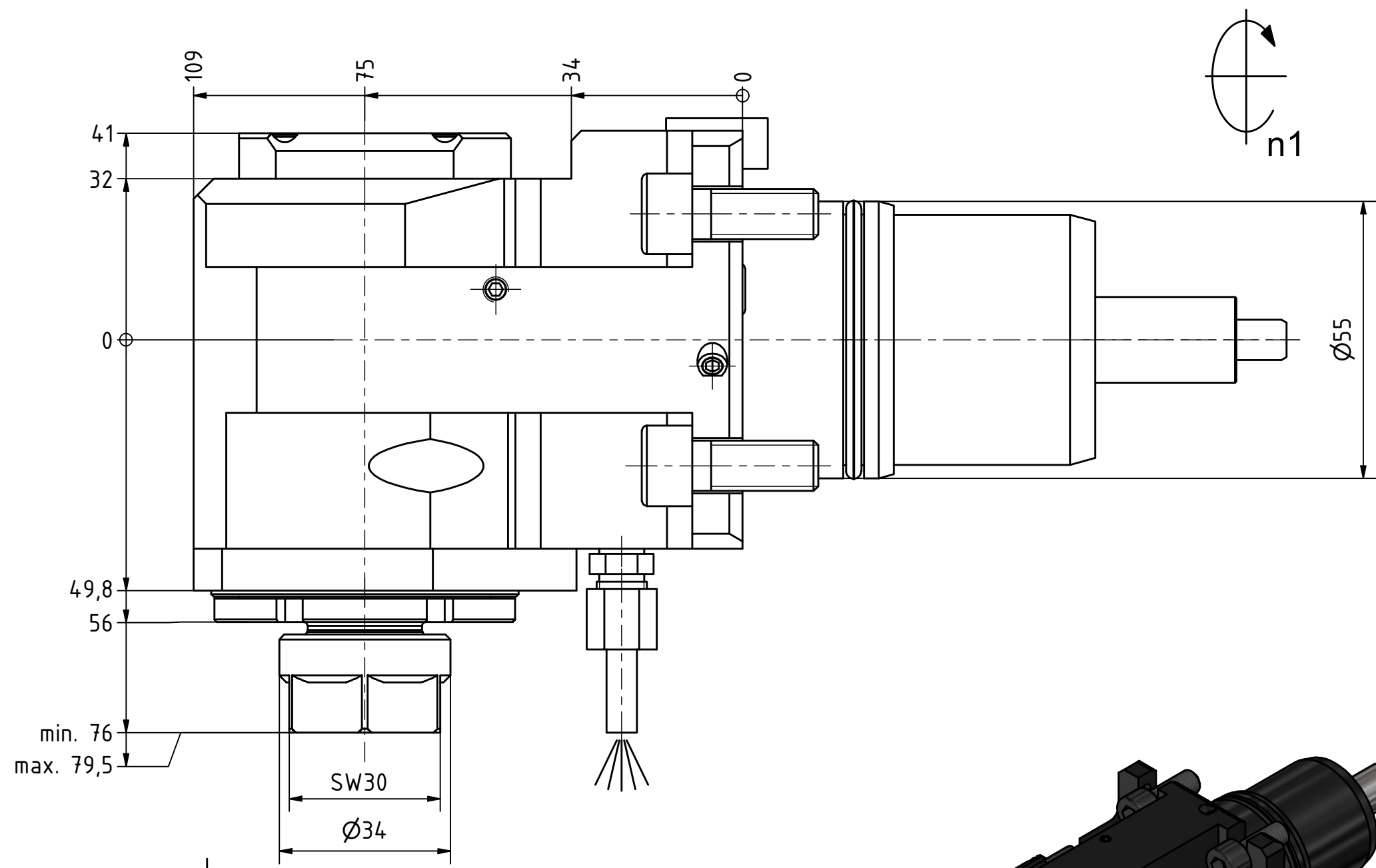

Hakenschlüssel
mit Nase
Hook wrench with
nose end
DIN1810 A 58x62

Spannzange / collet ER20 DIN6499
Spannbereich / clamping range: 1,0 - 13,0

Gewindebohrzange / tapping collet
ET-1-20 M2-M6

Copyright **EWS Tool Technologies**
Weitergabe und Vervielfaeltigung dieser Unterlage,
Verwertung und Mitteilung ihres Inhalts nicht
gestattet, soweit nicht ausdrecklich zugestanden.
Zuwaiderhandlungen verpflichten zu Schadenersatz.

Bemerkung - Note	

Technische Daten - technical data	
Weight	= 4.970 [kg]
Torque max. (M1/M2)	= 24 / 12 [Nm]
Speed max. (n1/n2)	= 6000 / 12000 [1/min]
Gear ratio (i)=n1:n2	= 1:2

Benennung - Title	
Radial Bohr und Fräskopf	
Radial drilling and milling head	

EWS Tool Technologies	EWS Weigele GmbH & Co. KG Maybachstr. 1 D-73066 Uthingen www.ews-tools.de
	Nr. - No. 60.5520WT250BMT11

Technische Aenderungen vorbehalten! Subject to technical modifications!	IDENT: DEWS154156
REV: -/A	MNR. 226725

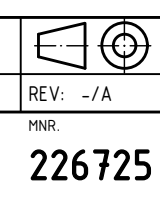

QR