

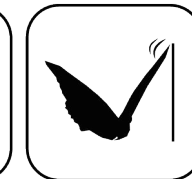

Ceramic Seal

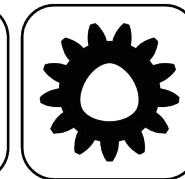

Butterfly Seal



Polygon Joint

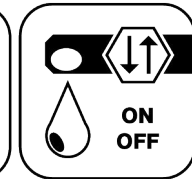

Coolant Management



Tech Details

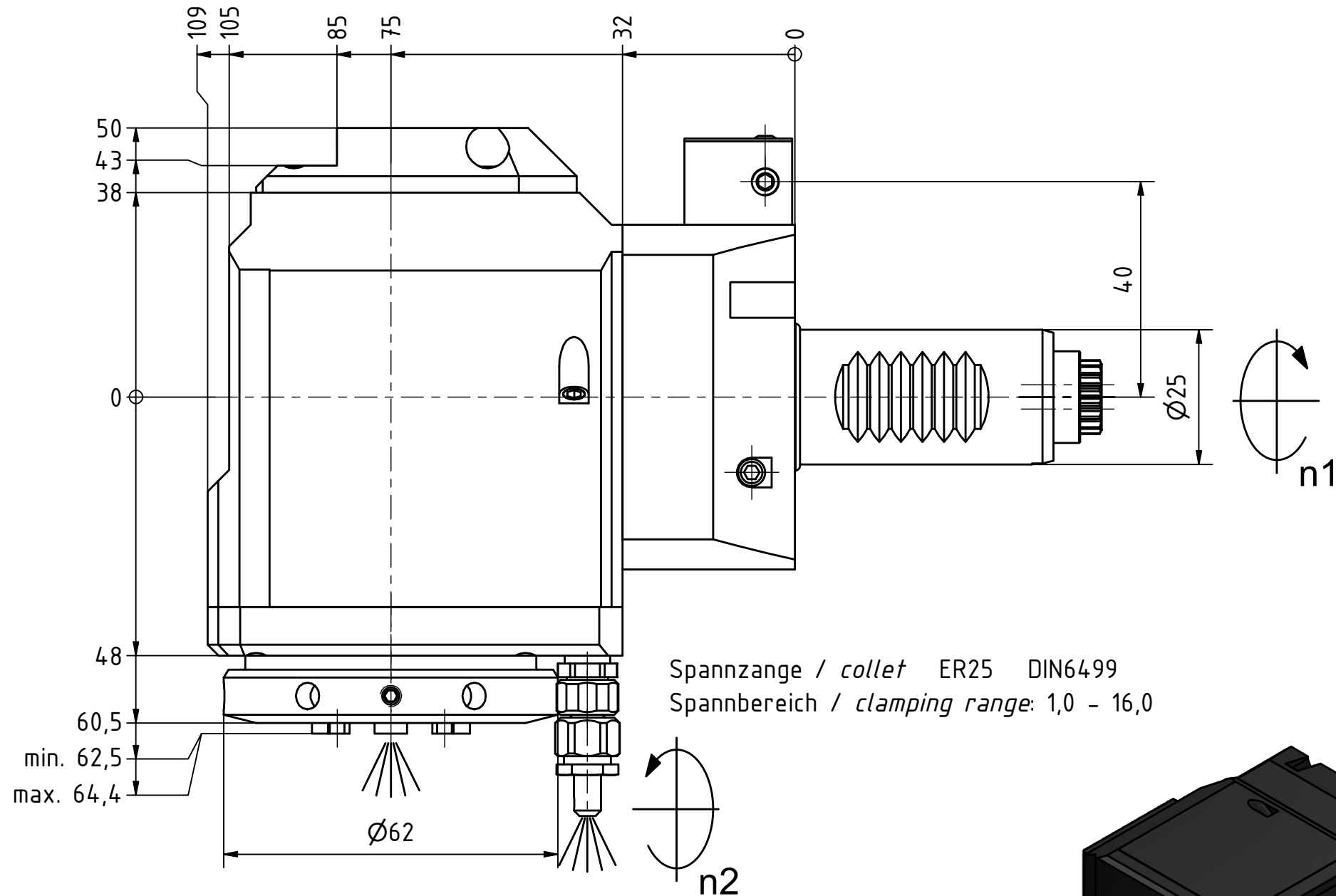

Spannzange / collet ER25 DIN6499
 Spannbereich / clamping range: 1,0 - 16,0

Doppelverzahnung Lizenz Traub
 double tooth system licence Traub

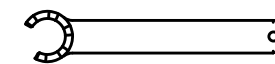
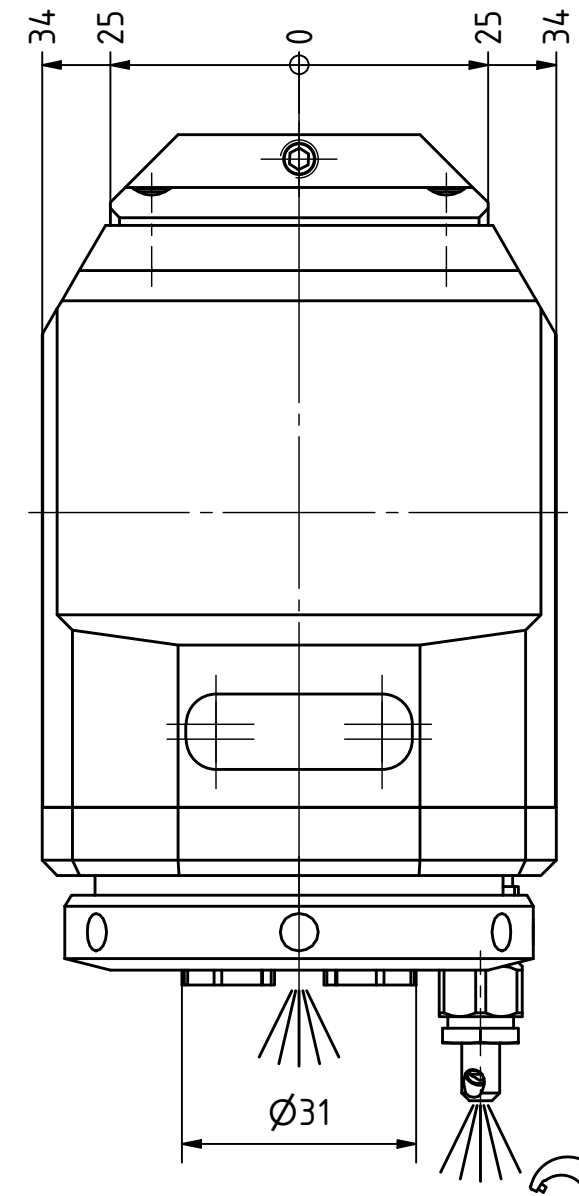
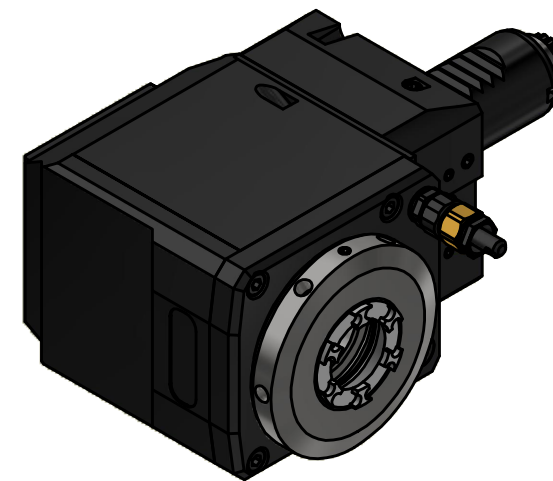

Spannzangenschlüssel für innenliegende Mutter
 Clamping wrench for internal collet
 225AX

Hakenschlüssel mit Zapfen
 Hook wrench with fixed pin
 DIN1810 B 58x62

Copyright **EWS Tool Technologies**
 Weitergabe und Vervielfaeltigung dieser Unterlage, Verwertung und Mitteilung ihres Inhalts nicht gestattet, soweit nicht ausdrecklich zugestanden. Zuwiderhandlungen verpflichten zu Schadenersatz.

Innen- und Aussenkuehlung / Inside and outside coolant supply
 Kuehlmittelfiltrierung 50μ / coolant filtration 50μ

Bemerkung - Note
 Für Trockenlauf geeignet!
 Use without coolant fluid allowed!
 mit Kegelrollenlager
 with taper roller bearing(s)

Technische Daten - technical data
 Weight = 3,871 [kg]
 Torque max. (M1/M2) = 25 / 25 [Nm]
 Speed max. (n1/n2) = 5000 / 5000 [1/min]
 Gear ratio (i)=n1:n2 = 1:1
 Pressure (pmax) = 70 [bar]

Benennung - Title
Radial Bohr und Fräskopf
Radial drilling and milling head



Nr. - No.
60.2525KRL5480RLIKDIM

Technische Aenderungen vorbehalten!
 Subject to technical modifications!
 IDENT: DEWS154536

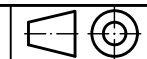

REV: -/A

MNR.

226723

