

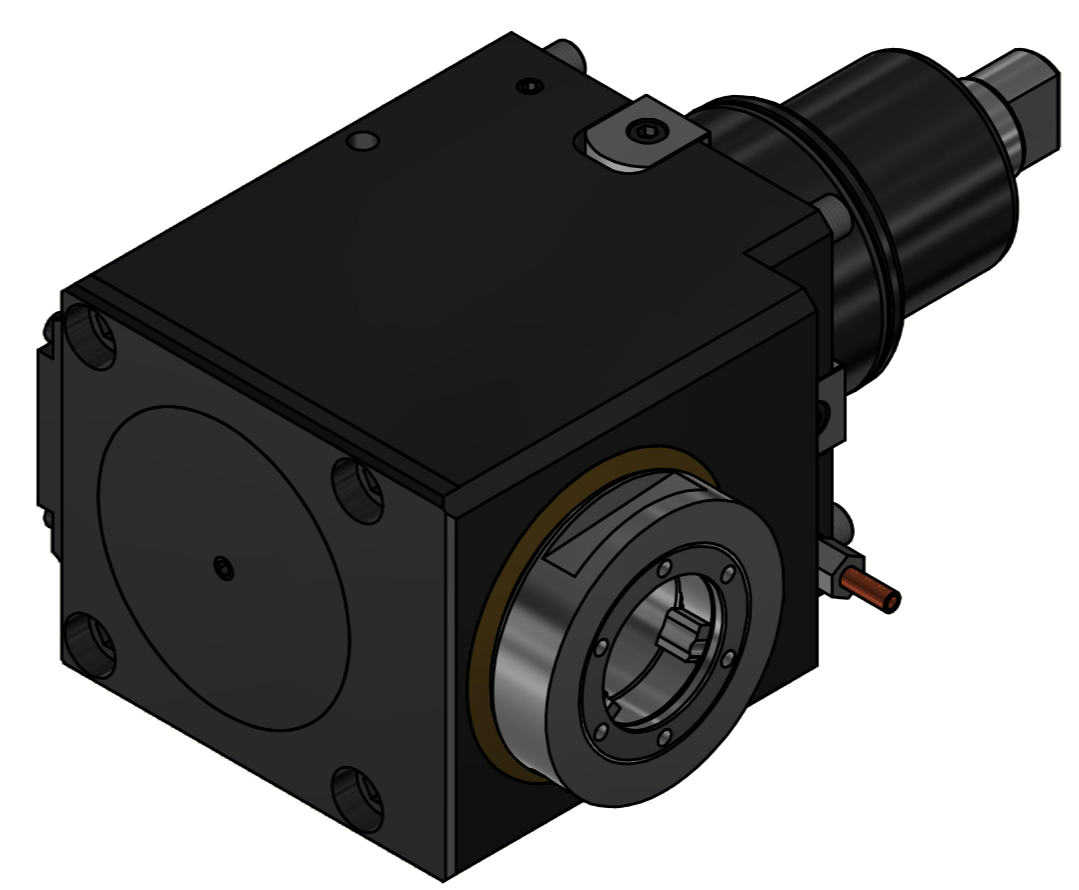

Ceramic Seal

Tech Details

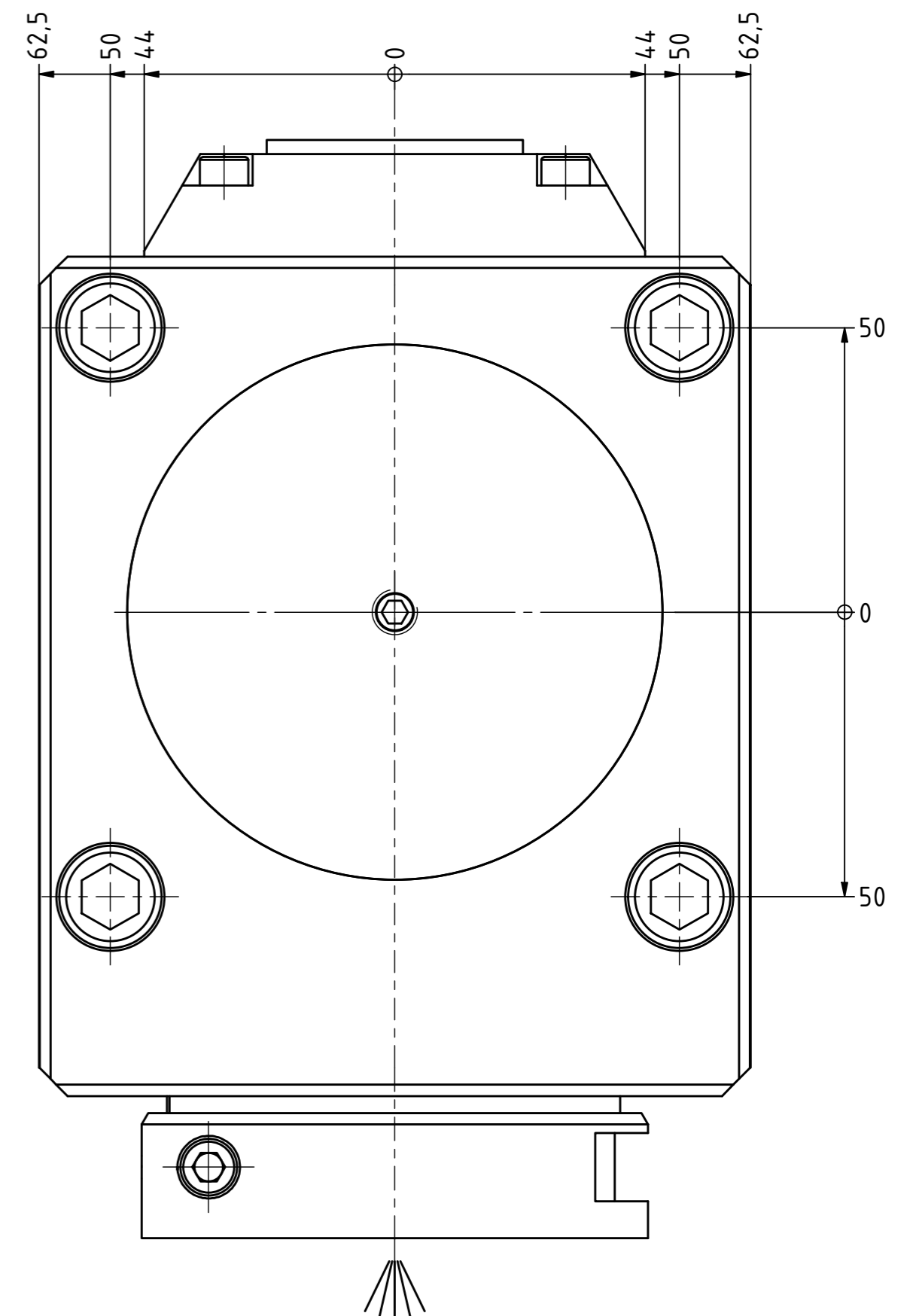
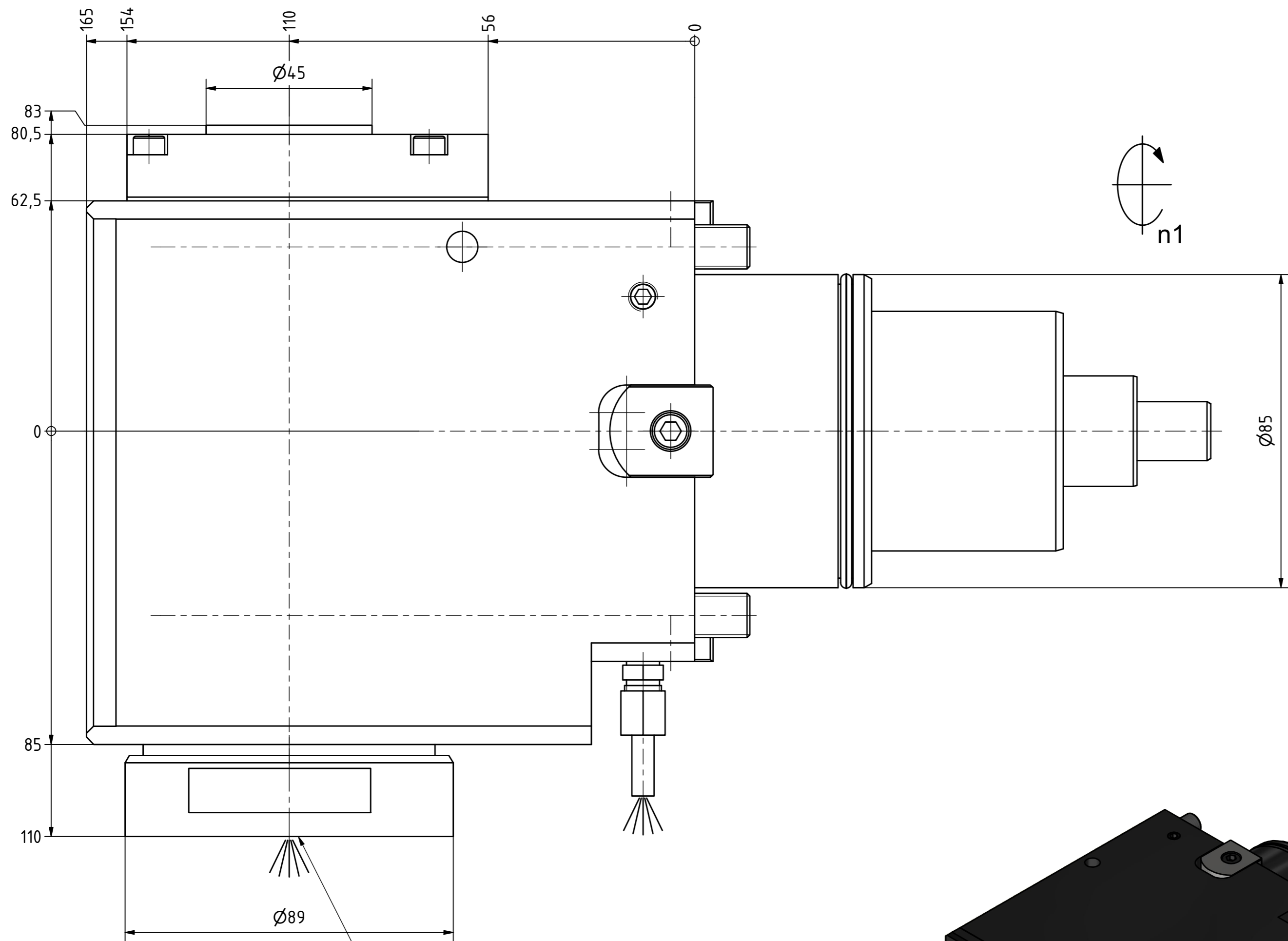

EWS-Varia V5

n2

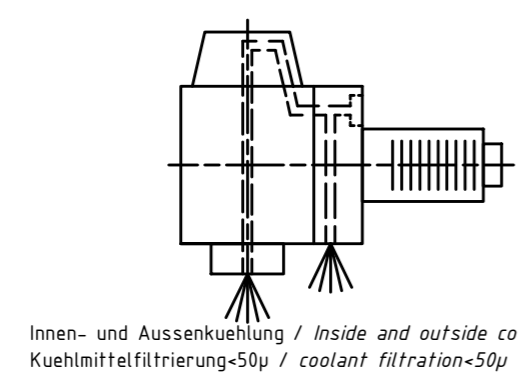

Innen- und Aussenkuehlung / Inside and outside coolant supply
Kuehlmittelfiltrierung-50µ / coolant filtration-50µ

Bemerkung - Note
Für Trockenlauf geeignet!
Use without coolant fluid allowed!

Technische Daten - technical data	
Weight	= 22.618 [kg]
Torque max. (M1/M2)	= 100 / 50 [Nm]
Speed max. (n1/n2)	= 4000 / 8000 [1/min]
Gear ratio (i)=n1:n2	= 1:2
Pressure (pmax)	= 70 [bar]

Benennung - Title
Radial Bohr und Fräskopf
Radial drilling and milling head

EWS Tool Technologies	EWS Weigle GmbH & Co. KG Maybachstr. 1 D-73066 Uhlingen www.ews-tool.de	Technische Aenderungen vorbehalten! Subject to technical modifications!	
	Nr. - No. 60.85V51809IKD11X110	IDENT: DEWS237175 REV: -/B	
		MNR. 226709	

Copyright **EWS Tool Technologies**
Weitergabe und Vervielfaeltigung dieser Unterlage,
Verwertung und Mitteilung ihres Inhalts nicht
gestattet, soweit nicht ausdruercklich zugestanden.
Zuwaiderhandlungen verpflichten zu Schadenersatz.