

Doppelverzahnung Lizenz Traub
double tooth system licence Traub

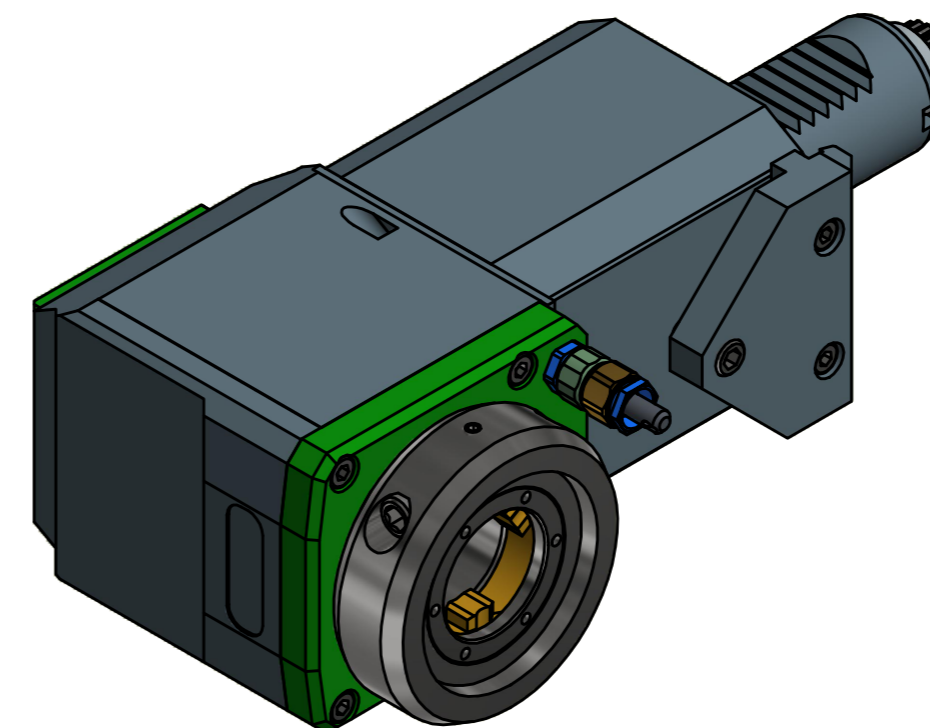

Copyright **EWS Tool Technologies**
Weitergabe und Vervielfältigung dieser Unterlage,
Verwertung und Mitteilung ihres Inhalts nicht
gestattet, soweit nicht ausdrücklich zugestanden.
Zuwendungen verpflichten zu Schadenersatz.

<p>Bemerkung - Note</p> <p>mit Kegelrollenlager with taper roller bearing(s)</p>	<p>Technische Daten - technical data</p> <p>Weight = 5,276 [kg]</p> <p>Torque max. (M1/M2) = 20 / 40 [Nm]</p> <p>Speed max. (n1/n2) = 8000 / 4000 [1/min]</p> <p>Gear ratio (i)=n1:n2 = 2:1</p>	<p>Benennung - Title</p> <p>Radial Bohr und Fräskopf Radial drilling and milling head</p>	<p>EWS Tool Technologies EWS Weigle GmbH & Co. KG Maybachstr. 1 D-73066 Uhlingen www.ews-tools.de</p>	<p>Technische Änderungen vorbehalten! Subject to technical modifications!</p> <p>IDENT: DEWS153352</p> <p>REV: -/A</p>	<p>Nr. - No. 60.30VX3KRLE365RLI2EL</p> <p>MNR. 226636</p> <p>QR</p>
--	---	---	--	--	--